



COMAC CAL

**CZECH PRODUCER
AND DEVELOPER
OF MEASUREMENT
AND SENSOR TECHNOLOGY**

FLOW 33

Ver. 2.16

Installation and technical conditions

Date of issue 18/06/2019

WWW.COMACCAL.COM

Contents:

Description of device	3
Scope of delivery	3
Storage conditions	4
Warranty	4
Installation in pipeline	5
Important information for selection of location	5
Sources of disturbances	5
Installation examples	6
Actual installation in pipeline	8
Installation check	15
Wiring	16
Meter wiring	16
Impulse output OUT1/OUT2	17
Status output OUT2	18
Current output	18
Feasible output configurations	18
BLUETOOTH service interface	19
Wiring check	19
Putting into operation	20
Technical data	22
Factory settings	24
Table with flow ranges for individual DN sizes	25
Basic sensor sizes	26
Nomogram for quick proposal of the measured place	30
Reduction in DN pipe	30
Failures and their symptoms during measurement	31
Flow sensor cleaning	31
Service	31
Order code	32
Returning the meter to COMAC CAL s.r.o.	33
Supplement	34
FLOW 33 BT Setup	34
Supplement	40
FLOW 33XM	40

Description of device

The FLOW 33 meter is based on measurement principle by a well-known Faraday's electromagnetic induction law according to which an electric voltage is induced during the flow of a conductive liquid through the flow meter magnetic field. This is picked up by two electrodes in direct contact with the measured medium and evaluated in the electronic unit.

The FLOW 33 type of induction meters are suitable exclusively for measurement of volumetric flow of electrically conductive liquid substances with a minimum conductivity of 20 $\mu\text{S}/\text{cm}$ (at a lower conductivity, upon agreement with the manufacturer).

Meters are designed for flow measurement where the velocity of liquid is in the range of 0.01 ÷ 12 m/s. The best measurement accuracy can be obtained in the range of 1 ÷ 10 m/s.

Scope of delivery

Accessories vary according to the variant of flow sensor and above standard optional features.

Threaded design

Electronic evaluation unit in a compact design (the electronic unit is integral part of the flow sensor), flow sensor, connecting grounding cable, installation manual.

Sandwich design

Electronic evaluation unit in a compact design (the electronic unit is integral part of the flow sensor), flow sensor, connecting grounding cable, installation manual.

Flanged design

Electronic evaluation unit in a compact design (the electronic unit is integral part of the flow sensor), flow sensor, connecting grounding cable, installation manual.

Food industry design

Electronic evaluation unit in a compact design (the electronic unit is integral part of the flow sensor), flow sensor, adapter piping connection according to DIN 11851, installation manual.

Storage conditions

The temperature during transportation and storage of the meter must be within the range of -10 °C to 50 °C.

Wooden boards installed on the flanges in the factory are used for protection of lining on the flanges during storage and transportation (for PTFE lining). Remove these protective boards just before installing in the pipeline!!!

Do not lift the flanged meters by the transducer head or by the connecting box of the detached design during transportation! Use slings and place them round both process connections for transportation of meters up to DN125 (chains may damage the meter head)! Use only the metallic lugs on the flange for transportation, lifting and installation of the sensor in piping in case of DN150 and bigger!!!

Warranty

Unprofessional installation or using the induction meters (devices) may result in a loss of warranty as well as failure to comply with installation or operating conditions according to this manual.

Installation in pipeline

Important information for selection of location

Outdoor conditions

It is necessary to ensure that the flow sensor is not exposed to weather effects and that the measured medium cannot freeze in the flow sensor as it would damage the measuring tube.

In case of outdoor location of the electronic evaluation unit, the manufacturer recommends using a protective box or a roof to avoid direct solar exposure so that the evaluation electronics cannot get overheated.

Sources of disturbances

The following items rank among the most frequent sources of disturbances to the steady flow of liquid:

- Abrupt changes in pipe cross-section if not performed as a cone with an angle of $\alpha \leq 7^\circ$ (where α is the angle made by bevelled walls of the pipe reduction).
- Incorrectly centred sealing, low ID sealing or sealing made of soft elastic materials which are pushed out into the interior pipe cross-section after flanges are tightened.
- Anything interfering in the flow of liquid, for example thermowells, branch pipes, T-pieces, bends, elbows, slide valves, cocks, flap valves, shut-off valves, control valves, butterfly valves and check valves. Pipe outlets from tanks, heat exchangers and filters.
- No intensive magnetic fields in the proximity of the induction flow sensor (detector) must be present.

No sources of disturbances affecting the steady flow must be present in the straight pipeline sections. They must be located in the piping after the flow sensor or at the farthest distance before it. Sources of disturbances may substantially reduce the measuring range and accuracy of the flow meters.

Vibration

We recommend supporting the connecting pipes on both sides of the meter for partial elimination of vibrations. Levels and range of vibrations must be under 2.2 in the frequency range of $20 \div 50$ Hz according to IEC 068-2-34. If the pipeline is exposed to excessive vibrations (e.g. from pumps), using compact meters is not recommended.

Actual location

The flow sensor (detector) must not be at the top position of the pipe which may be airlocked, or in declining or even in horizontal pipelines with open ends in which air may penetrate. Impurities may accumulate during long-term measurement of very low flow rates $Q < 0.1$ m/sec. There must be a sufficient pressure in the place of flow sensor installation so that the expulsion of gas or vapour bubbles from the liquid is avoided. Little bubbles that always occur in liquids may accumulate at any of the electrodes and this may result in incorrect operation of the meter. Gas bubbles are expelled also at an abrupt pressure drop. Therefore, butterfly valves and similar elements should be located **after the flow sensor**. For the same reason, the flow sensor should not be placed at the suction side of the pump. To prevent the bubbles from accumulation at a low flow in the flow sensor, it is suitable, e.g. that the pipe is slightly ascending or that the flow sensor is located in the vertical section of the pipeline.

If the meter is populated with measuring electrodes only (2 or 3 electrodes located **beyond the upper profile** of the tube), it is necessary for proper function of the meter, to fill up the flow sensor with the fluid to be measured so that erroneous readout of quantity of liquid passing through the meter can be avoided when the pipe is empty. It is necessary to select the location of the meter in such a way that the flow sensor aeration can be avoided. In the case of an open system, the flow sensor is placed in the bottom position of the U-profile pipework, ensuring that the fluid will not flow out of the sensor.

In the case that the sensor is equipped with an empty pipe testing electrode (3rd or 4th electrode in the upper part of the measuring tube profile), there is no risk of erroneous readout of quantity of liquid passing through the meter due to aeration of measuring electrodes. This function must be activated in PARAMETERS (EMPTY TUBE TEST) menu. If it be to the contrary, the same conditions apply as if the testing electrode is not populated.

The function of empty tube detection in horizontal mounting position operates correctly only if the evaluation unit is oriented upwards (see Fig. below). Alternatively, it is not possible to ensure that the activation of empty tube detection in case of partly filled or empty pipes will take place.

Due to the principle, it is necessary that the maximum conductivity of medium is 6000 μS for ensuring the functional evaluation of empty tube. Beyond this limit, errors may occur in empty tube test, and in this case, it is necessary to deactivate the empty tube test. If the conductivity of medium is beyond the permissible range, the meter may, despite the flooded system, register empty pipeline and the measurement will not start.

In case of any intervention into the measuring circuit must be accessed like a pipe is fulfilled of medium, and regardless of the displayed information "empty pipe test" on the meter LED !!!

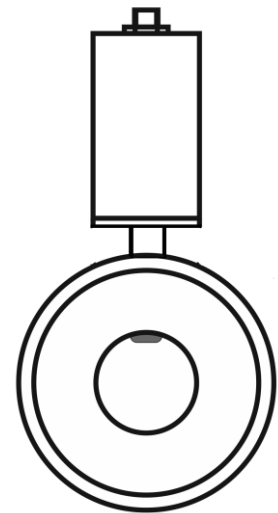

Installation examples

Trouble-free and exact operation of the meter is dependent on its correct location in the system. The most frequent methods of the placement are shown in the following figures:

Recommended installation locations

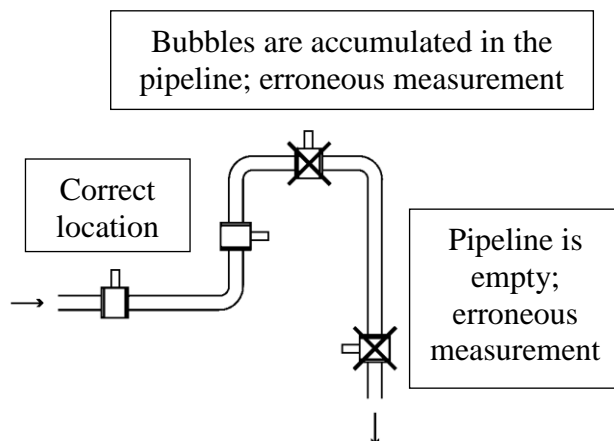

Downtake pipe

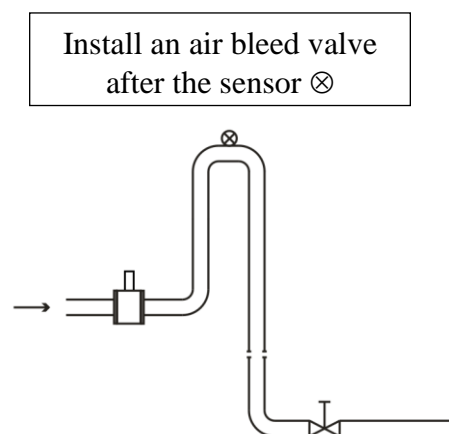

Horizontally laid pipeline

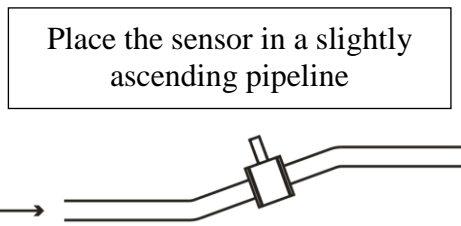

Long pipeline

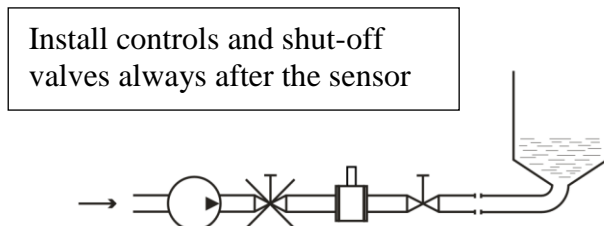

Free inlet or outlet

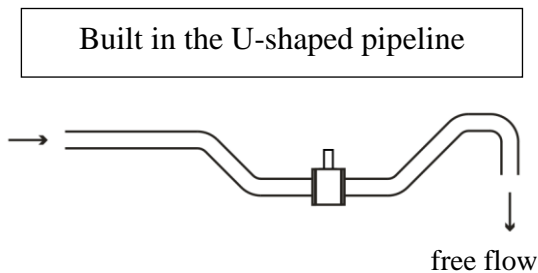

Pumps

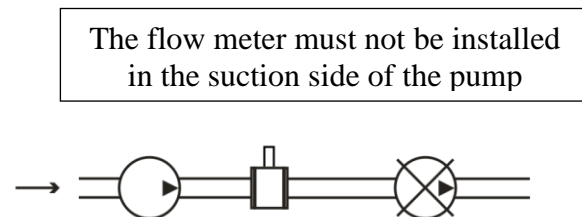

The flow of liquid flow in the flow sensor should be **steady and free of whirling**. For this reason, straight sections of pipeline with the same ID as that of the flow meter before and after the flow sensor (with permissible deviation of +5%). Recommended minimum length of straight sections is $5 \times d$ before the flow sensor and $3 \times d$ after the flow sensor where d is the inside diameter of the meter in millimetres. The same principles apply before and after the flow sensor in case of bi-directional flow measurement.

Recommendations

- In case of whirled up flow, extend the calming sections of pipeline or integrate a flow conditioner.
- When blending a mixture of substances, it is necessary to install the flow meter either before the point of blending or at a sufficient distance after it ($30 \times d$ min. where d is the inside diameter of the meter in millimetres), otherwise it will result in instability of indication.
- When plastic pipeline is used or in case of metallic pipes with internal non-conductive layer, earthing rings are needed.
- Do not install the sensor at the suction side of the pumps; this will eliminate the risk of vacuum and possible damage to the measuring tube lining.
- Pumps, bends and elbows found closely in succession in various levels should be at a distance of $20 \times d$ at least before the flow sensor. In case of a separate elbow or bend, the placement $10 \times d$ before the meter is recommended.
- When piston pumps, diaphragm pumps, and flexible tube pumps are used, it is necessary to install a pulse damper in the system.
- In order to provide the highest accuracy, it is important to ensure permanent flooding for the sensor (for example, by installation of the sensor in the U-shaped pipeline) even if the sensor is equipped with empty tube test. This will serve as an additional safety measure for detection of non-flooded tube.

The responsibility for suitability and adequacy of application of induction flow meters is borne by the designer or possibly the user himself.

Actual installation in pipeline

When welding both counter-flanges to the pipelines, it is necessary to maintain their **alignment** so that levelness of bearing surfaces of the flanges onto the front faces of the detector is ensured (at the same time, this must not be achieved by unequal tightening of the bolts as there is a risk of leakage due to thermal loading in the future or the measuring tube may break during such tightening). The difference of L_{MAX} and L_{MIN} distances of the sealing surfaces of the flanges before the flow sensor is installed **must not be greater than 0.5 mm**.

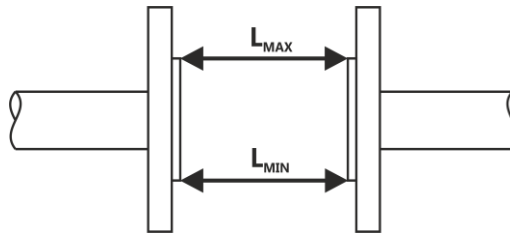

The opposition of the holes in the counter-flanges for the bolts should be ensured in the same manner and a sufficient room behind the flanges should be available for the bolts and nuts so that the actual installation of the sensor in pipeline and its attachment with the bolts is made possible.

The manufacturer recommends using an intermediate piece during welding. It is absolutely excluded to use the flow sensor as an intermediate piece due to thermal damage. The welding current must not run through the flow sensor during electrical welding. The installation of the flow sensor is carried out after welding, coating, building and similar works are completed.

The actual installation is performed by the fixation between the counter-flanges that are welded to the calming pipeline ($5 \times d$ before and $3 \times d$ in the direction of flow) whereas the liquid must run through the flow sensor in the direction **indicated by the arrow** on the sensor name plate.

During installation, do not lift the meter by the evaluation unit housing, possibly under the meter's metallic housing but always use slings round the process connection or use the lifting lugs on the flanges.

Installation position

The inductive flow sensor is installed in arbitrary position in vertical piping. In case of horizontal piping, it is necessary to make sure that the sensor is installed with its measuring electrodes in horizontal position. In case of the earthing electrode design, possibly with testing for empty pipeline, then the installation is always performed with the earthing reference electrode facing down (with the sensor terminal box, eventually with the evaluation unit facing upwards). Then the earthing reference electrode is in the bottom position and the empty tube sensing electrode is in the top position of the flow sensor.

Every time when the empty tube testing electrode is not covered with a liquid for 5sec at least, the flow meter will display the "Empty tube" status, and if it is necessary, it sends out an error message and stops taking measurement. The measurement accuracy is maintained in this way. Once the electrode is covered with the liquid again, the error message disappears and the flow meter starts taking measurement again.

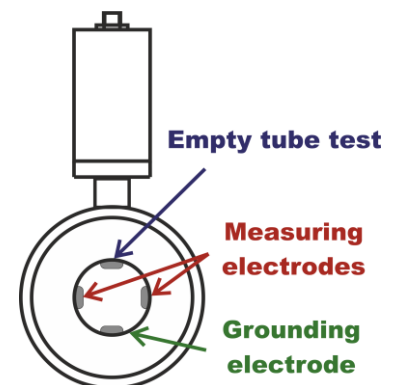

Measurement error caused by incorrect mounting installation

1) correct installation (flow sensor should be install in arbitrary position in vertical piping)

EMPTY TEST – ON

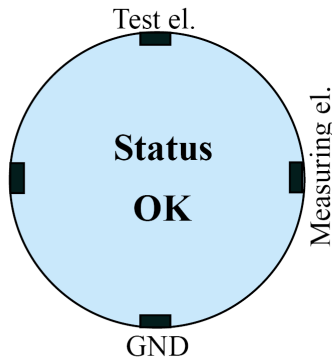
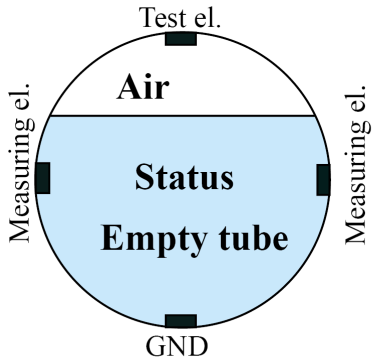

EMPTY TEST – OFF

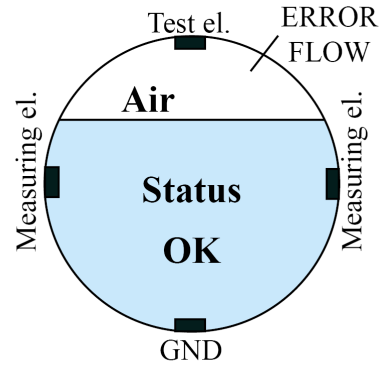

2) incorrect installation (placing the unit diagonally, Empty test – ON)

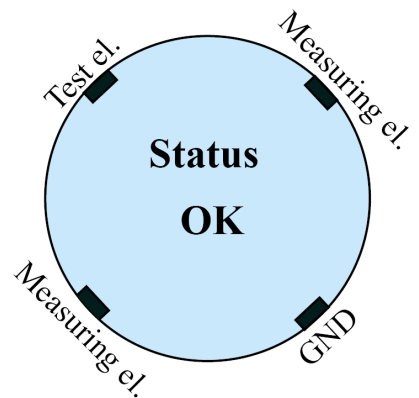
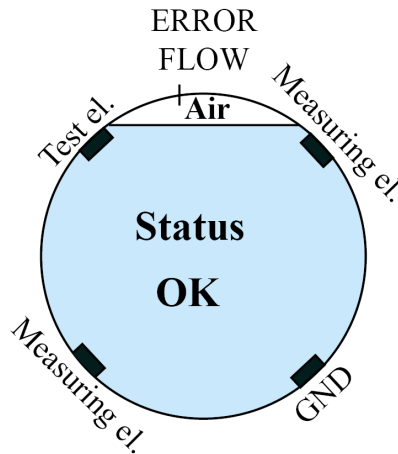
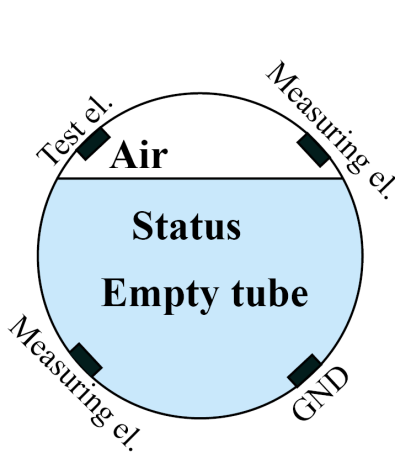

Installation in piping and placement of measuring electrodes in flow sensor

1) in the version without the earthed reference electrode and/or empty piping test (2 electrodes)

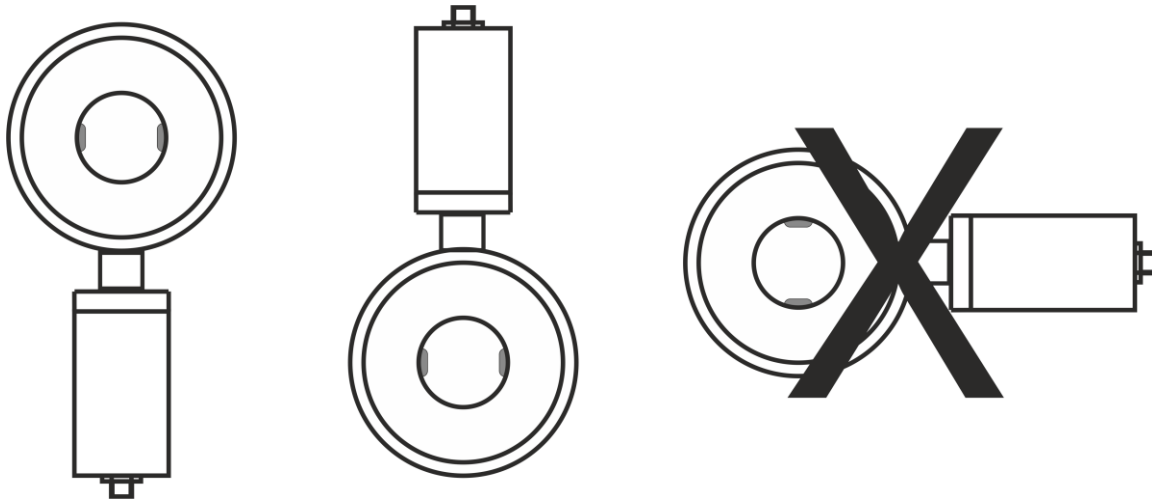

2) in the version with earthed electrode and/or empty piping test electrode (3/4 of the electrode)

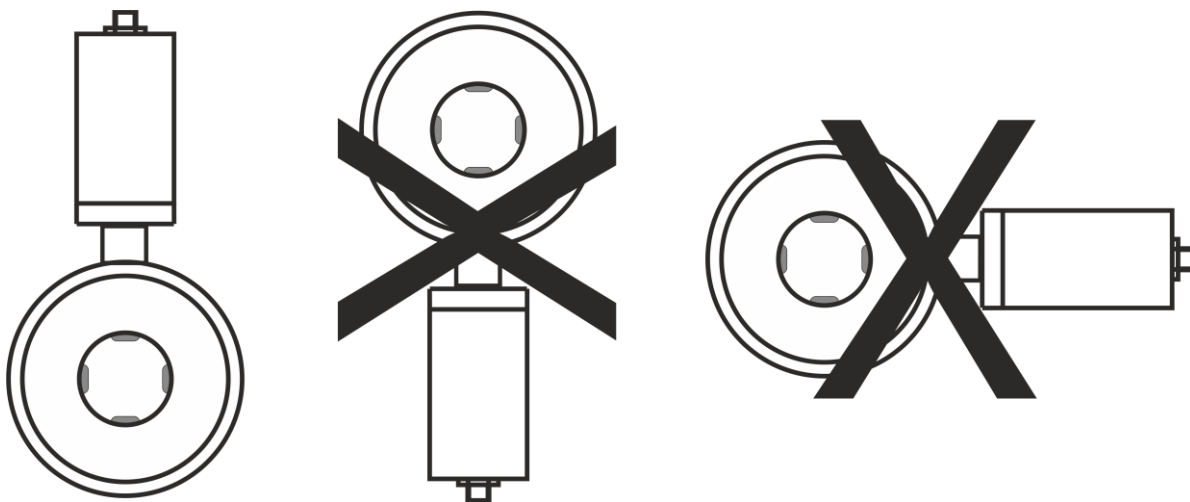

During installation, beware of:

- dropping the meter onto the ground and damaging the measuring tube or electronics
- contamination of the electrodes (do not touch the electrodes, otherwise they get contaminated)
- when additional sealing is used, avoid its interference in the flow profile of the detector between the flanges and the pipeline, otherwise the flow measurement error may be increased

Tightening torques

It is absolutely necessary to tighten the bolts and nuts equally by alternating sides and in the order shown in figure applying the maximum torque according to the table.

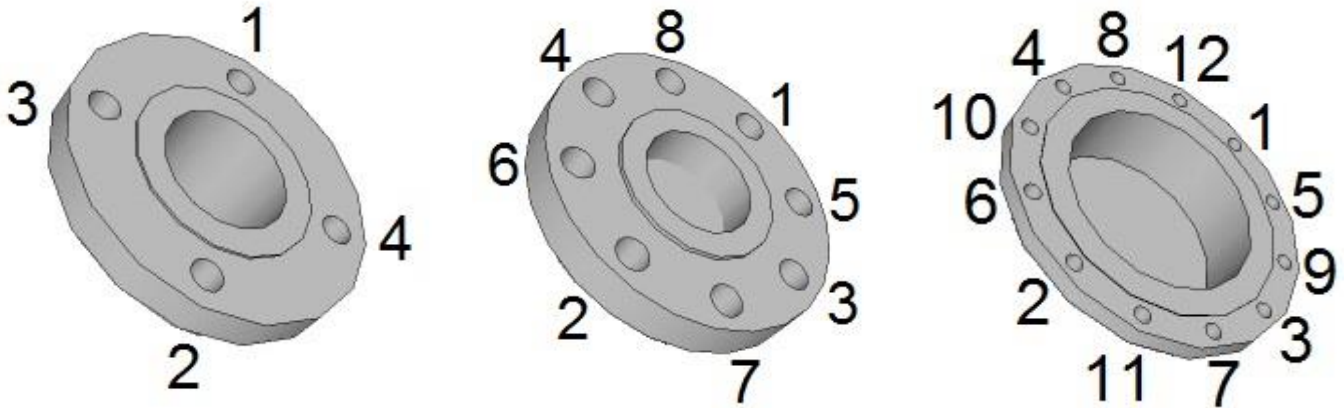

If the bolts are tightened too much during the installation of pipework components, deformation of the sealing surface may occur. In consequence, the torque values indicated in the table are used as a guidance for tightening the screws and bolts.

Table with tightening torques for screws/bolts (EN 1092-1):

Diameter nominal DN	PN 10			PN 16		
	Screws	Tightening torque [Nm]		Screws	Tightening torque [Nm]	
		Rubber	PTFE, PFA, ETFE, PVDF		Rubber	PTFE, PFA, ETFE, PVDF
10		10	15		10	15
15	4 x M12	15	20	4 x M12	15	20
20		20	25		20	25
25		20	25		20	25
32		20	25		20	35
40	4 x M16	20	25	4 x M16	20	35
50		20	45		20	45
65		20	46		20	46
80		20	48		20	48
100	8 x M16	20	50	8 x M16	20	50
125		20	80		20	65
150	8 x M20	24	90	8 x M20	27	90
200		27	115	12 x M20	35	80
250	12 x M20	35	95	12 x M24	55	100
300		50	100		80	110
350	16 x M20	60	70	16 x M24	95	105
400	16 x M24	75	120	16 x M27	140	150
500	20 x M24	100	150	20 x M30	250	230
600	20 x M27	165	240	20 x M30	400	360

Diameter nominal DN	PN 25			PN 40		
	Screws	Tightening torque [Nm]		Screws	Tightening torque [Nm]	
		Rubber	PTFE, PFA, ETFE, PVDF		Rubber	PTFE, PFA, ETFE, PVDF
10	4 x M12	15	15	4 x M12	15	15
15		20	20		25	25
20		25	25		25	25
25		25	25		25	25
32		25	35		25	40
40	4 x M16	25	35	4 x M16	35	50
50		35	45		35	60
65		35	46		45	55
80	8 x M16	40	48	8 x M16	45	60
100	8 x M20	40	55	8 x M20	50	75
125	8 x M24	50	110	8 x M24	70	120
150		57	115		75	136
200	12 x M24	68	100	12 x M27	85	145
250	12 x M27	88	120	12 x M30	105	220
300	16 x M27	95	125	16 x M30	115	250
350	16 x M30	115	200	16 x M33	140	-
400	16 x M33	135	255	16 x M36	165	-
500	20 x M33	350	430	20 x M36	-	-
600	20 x M36	600	740	20 x M45	-	-

In case of using a corundum or thermoplastic tube, the same torques apply as in case of using the PTFE tube according to the given pressure series.

Threaded connection (EN 10226-1):

Diameter nominal DN	Process connection [inch]	Tightening torque [Nm]
10	3/8"	8
15	1/2"	10
20	3/4"	21
25	1"	31
32	1 1/4"	60
40	1 1/2"	80
50	2"	5
65	2 1/2"	6
80	3"	15
100	4"	14

If you do not find your size or structure in the Torque Table, it is a special or non-standard design. In such a case, contact the manufacturer for more detailed information.

It is necessary to do the tightening three times, whereas for the first time, to 50% of the maximum torque according to the above given Table. For the second time, to 80% and for the third time, to 100% of the maximum torque. We recommend checking the screws/bolts for tightening some 24 hours after installation of the meter.

When installing the flow sensors over 200 mm, it is necessary to follow, except for the above mentioned rules, also simultaneous tightening of parallel screws on both opposite flanges to avoid possible damaging the electrodes or the measuring tube (symmetrical tensioning of the lining).

If the flanged joint is not tight, although all of the screws are tightened closely, **these must not be tightened more** but slackened on the opposite side to the untightness and tightened on the other side. If the untightness manifests itself even after that, it is necessary to check the sealing surfaces for scratches or mechanical impurities. If the scratches or any other damage are deeper than some 15% of the thickness of the flange, it is possible to remove them using fine emery paper.

In case of the threaded connection, it is necessary to check, while tightening, the screwed connection on the sensor so that torsional displacement is avoided.

Seal

The turned up part of the lining does not carry out the function of sealing so it is necessary to insert the appropriate seal precisely centred between the sensor and the pipeline. If the sealing extends in some place into the flow profile, it makes whirls and reduces the measurement quality. Use the seals compatible with the liquid and 5mm thick. Do not use graphite or any other electrically conductive material to hold the sealing in place during installation. It could influence the measuring signal accuracy.

Earthing

For reliable and correct operation of the induction sensor it is necessary to provide proper protective and working earthing. The earth line must not transmit interference voltages so the other electrical devices must not be earthed by means of this line.

The flow sensor is provided with the M5 earthing screw of stainless steel with a washer and nut for proper connection of the sensor body with both counter-flanges of the metallic pipeline. The earthing cable lug is screwed there and it should be conductively connected with the counter-flanges. On the counter-flanges, it is recommended their connection to the welded crews or into a threaded hole. Connecting under the fixing screws of the flange is not suitable as they may corrode with time and cause failures in measurement.

However, if it is not ensured that the counter-flanges are in direct contact with the measured media and they are conductive, the earthing rings must be used, refer hereinafter.

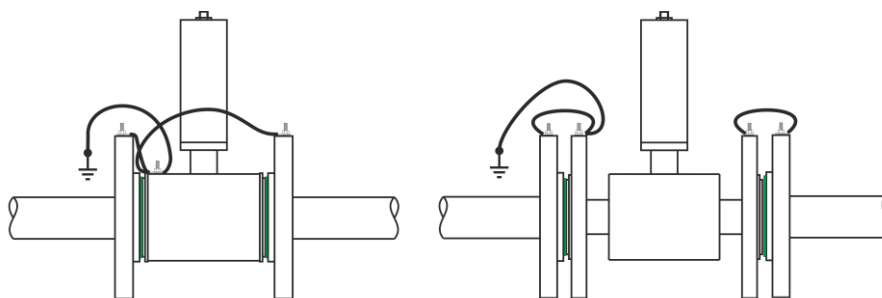

Earthing rings

Using for a plastic pipeline or in case of metallic pipelines with internal plastic lining turned up or pulled out to the front faces of the pipeline flanges. Conductive earthing rings of stainless steel create conductive connection with the measured substance. Usually, potential equalization is carried out by means of the reference earthing electrode in the measuring tube. In exceptional cases, the equalizing currents may run through the reference electrode based on the device earthing conception. This may lead to deterioration of the sensor, e.g. by electrochemical disintegration of the electrodes. In such cases, it is **necessary** to use the earthing rings for potential equalization. This holds true for two-phase or two-component flows in which the medium is blended badly or its components cannot be blended. In general it can be said that using the earthing rings is always the protection against stray currents and the warranty of correct measurement at the same time.

The flow sensor is provided with the earthing screw of stainless steel for the earthing cable supplied with the mounting accessories. Then this cable must be conductively connected with the earthing rings.

The earthing rings are not part of our standard package and must be ordered separately. Chemical durability of the material must correspond with the liquid to be measured; it is usually made of the same material as the sensor electrodes. While mounting, it is necessary to insert seals in both sides of the earthing ring and take care that no part extends to the internal profile of the sensor (whirling and turbulence of the medium).

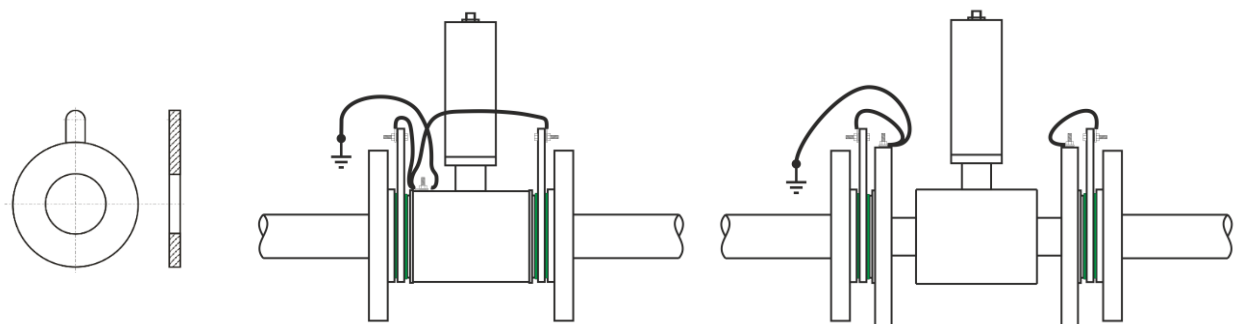

Electrodes

The electrode material must be selected according to chemical resistance to the liquid to be measured. The purity of the electrodes may have an influence on measurement accuracy, their heavy foulness may cause even the interruption of the measuring function (isolation from the liquid). It is not necessary to clean the electrodes right after delivery before their installation in the pipeline. If the electrodes indicate signs of foulness, clean them with a soft cloth or use a chemical cleaning agent. Mind damaging to the lining! During routine operation, in case of a great majority of liquids, it is not necessary to clean the flow meter for the entire operation period of the flow sensor; self-cleaning by flow of the liquid is sufficient (recommended velocity is over 2 m/sec).

PTFE, PFA, ETFE lining

Meters with PTFE lining are equipped with protective covers to prevent the sealing surfaces from damaging during transportation or storage and from changing the shape (due to elastic memory of the PTFE material, it is restraightened to the tube). Protective covers may be removed only right before the installation. If these covers are removed due to a check, it is necessary to replace them immediately.

Carry out the installation at the lowest point of the pipeline to avoid the occurrence of vacuum. Never detach and damage the rim of the PTFE lining turned up to the of flow sensor faces. Remove the covers from the inlet and outlet sides right before insertion of the sensor between the pipeline flanges and replace them with metal plates (0.3 ÷ 0.6 mm thick). After insertion of the sensor, remove the metal plates and install the screws/bolts.

Installation check

After installation of the flow sensor in the pipeline, the following must be checked:

- According to the name plate, if there is a relevant meter in the given measuring point (pressure, temperature, dimension, etc.).
- If the direction of the arrow on the device is in agreement with the direction of the flow in the pipeline.
- Correct position of the measuring electrodes (horizontally).
- Correct position of the electrode for empty pipeline detection (up).
- If all bolts (screws) are tightened properly.
- If earthing rings are used, then their correct installation and connection with the sensor.
- Accuracy of flow sensor earthing.
- Accuracy of execution of the pipeline calming section lengths
- If the sensor is protected against vibrations and mechanical damage.

Wiring

Workers performing wiring are subject to the requirements of Decree No. 50/1978 Coll. on activities on electrical equipment!!!

When the following operations are performed unprofessionally, the claim on warranty for the resulting errors becomes extinct!!!

Prior to any manipulation with the meter, switch off the power!!!

Meter wiring

Evaluation unit

As a standard, the evaluation unit is delivered for 24V DC \pm 15% /250mA supply voltage.

The flow meter signal outputs must only be connected to devices where accident protection is provided by safe low voltage and where generated voltages do not exceed the limits defined for safe low voltage.

Pinout for standard M12 socket on meter's body

8-pin M12 connector for 24V DC \pm 15%, power, impulse output and current loop

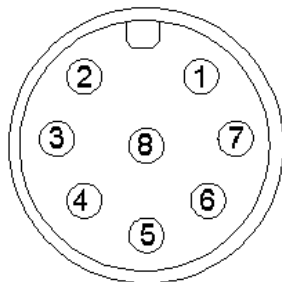

- 1 OUT2 status/impulse (collector – positive potential)
- 2 OUT1 impulse (collector – positive potential)
- 3 OUT1 impulse (emitter – negative potential)
- 4 OUT2 status/impulse (emitter – negative potential)
- 5 Analog output 4÷20mA -
- 6 Analog output 4÷20mA +
- 7 GND
- 8 +Vdd

Standard connection of the cable to the M12 connector against the socket on the meter's body:

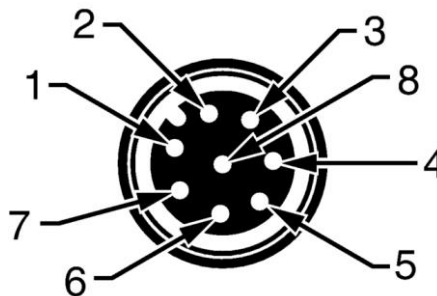

Impulse output OUT1/OUT2

The output of volumetric impulses is implemented by an optocoupler with a switching NPN transistor, the collector of which is connected to PIN 2 for OUT1 or to PIN 1 in case of OUT2 output and the emitter to PIN 3 for OUT1 or to PIN 4 in case of OUT2 output. Limit parameters of this optocoupler are 300V/150mA/100mW max.

The volumetric impulse output is used for remote transmission of volumetric impulses and for metrological verification of the flow meter. The conversion constant and the pulse width are adjusted arbitrarily (float data type) by means of the service communication interface. If OUT2 output is used in impulse output mode, the impulse constant is identical to OUT1 output.

Optocoupler loading should be selected so that its limit parameters cannot be exceeded.

Load characteristics ($I_f = 2.5\text{mA}$):

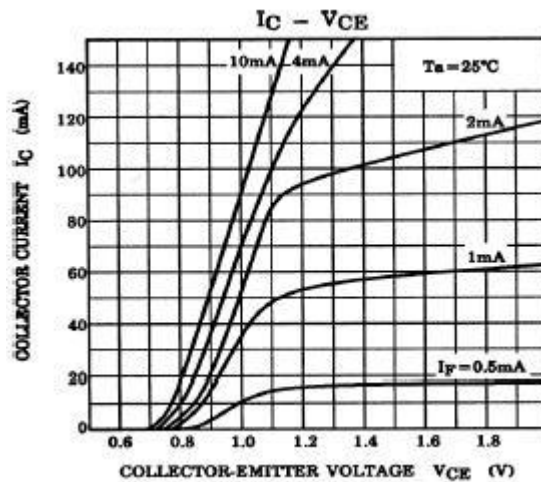

Wiring example:

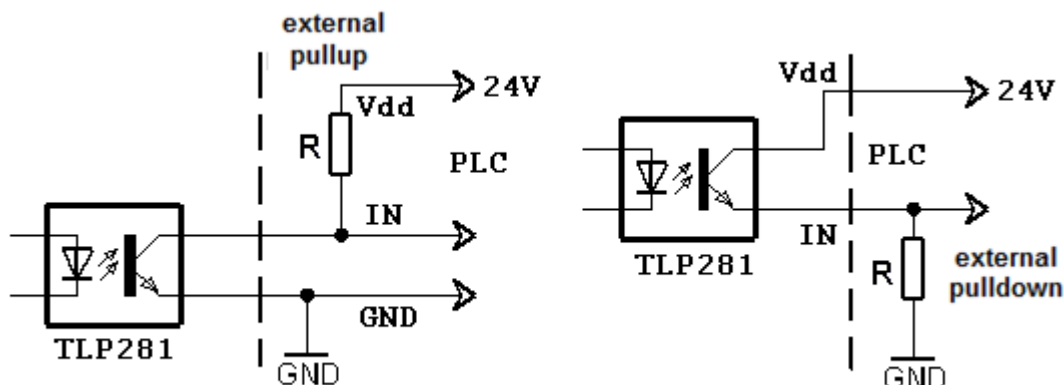

The maximum frequency of the impulse output is 900Hz with min. 250 μ s pulse width.

Status output OUT2

The output is implemented by an optocoupler with the parameters of OUT1/OUT2 impulse output. By means of control software, it is possible to select from three functions:

- Output Failure*
- Output Flow Direction
- Output as flow monitor (FlowSwitch)

*The failure is a state when the F33 meter does not take measurement and the yellow LED or red LED are on at the same time, indicating one of these states:

- Defective flow sensor
- No fluid in piping
- Measured signal is beyond limits (signal cannot be measured)

Current output

The current output is isolated from the meter itself by means of optocouplers. The current loop is connected to terminals 5 and 6. It is necessary to feed the current output from an external power supply. External power supply voltage U_e can be 12 up to 24 V.

The loop resistance must not be higher than $R = U_e / 0.02$ (Ω ;V).

As standard, it is set in such a way that with the maximum flow Q_{max} the loop current is 20mA and with the zero or negative flow, the loop current is 4mA.

The current value is directly proportional to that of the flow in the sample.

The flow limits of the current output are arbitrarily adjustable (float data type) by means of the service communication interface.

In case of a failure or due to the loss of power, the current output falls under 4mA (usually under 1mA) and thereby a higher-level system can detect the error state.

Passive current loop example:

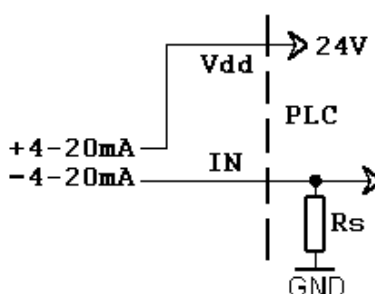

Feasible output configurations

OUT1 (impulse)	OUT2 (status/impulse)	Analog OUT
impulses in flow direction	status output – Failure	4-20mA in flow direction
impulses in flow direction	impulses in reverse flow direction	4-20mA in flow direction
impulses in both flow directions	status output – flow direction	4-20mA in both flow directions
impulses in flow direction	status output – flow monitoring (in flow direction only)	4-20mA in flow direction

BLUETOOTH service interface

For setting and service purposes, the meter is equipped with the Bluetooth SPP communication interface (9600Bd, sb, no parity). Setting can be performed by a device with Android or Windows operating systems (cell phone, tablet, etc.). Detailed diagnostics mode is then made possible via Windows OS.

In diagnostics mode, the meter transmits text information on its status periodically.

List of transmitted text messages:

Empty tube!	measuring tube empty
Electrode 1-interrupted!	sensing electrode 1 interrupted
Electrode 2-interrupted!	sensing electrode 2 interrupted
Signal outside measured window!	measuring signal beyond parameters
Null current detect-check coil or current source!	loss of excitation current
AD value: <value>	meter OK, AD converter value

Wiring check

After completion of wiring, it is necessary to check:

- Connecting cables for damage.
- Cables for pull relief.
- Correct connection of cables to terminals.
- Whether the supply voltage corresponds with the nameplate data.

Putting into operation

Prior to connection to power supply, check the device installation accuracy in accordance with “Installation in pipeline“ and “Wiring” chapters.

If the meter has no electrode for empty tube detection, do not connect the meter to power before filling the system with the fluid to be measured and power off the meter before system discharge.









It is important for ceramic measuring tube, while the piping is filled with a medium, to maintain gradual warming up or cooling down the ceramic measuring tube, always by 50°C at the most, and after 5 minutes every time. Failure to observe these conditions may result in destruction of the measuring tube.

If you wish the meter to take measurement as precisely as possible right after powering up, it is a good idea to fill the flow sensor with water, one or two days before its installation, so that all of its electrodes are flooded. Just before the installation, the water is discharged and the sensor is installed into piping. Right after installation, piping is filled with a medium so that the electrodes cannot dry off.

After the meter is powered up, the green LED on the top cover next to the M12 connector is lit, confirming the supply voltage on the control PCB and stabilization of parameters of the meter takes place afterwards (approx. 20sec). After that period of time, the meter starts measuring.

Meter status:

It is continuously displayed by two indicator LEDs located in the evaluation unit top cover (next to M12 connector). The meter status indicated by the LEDs can be as follows:

LED1	LED2	Description	Current output
 green	-	The meter is in good order and the flow is null or negative	4mA
 green	 blue is flashing	The meter is in good order and the flow is positive where the blue LED is indicating the transmission of volumetric pulses	4÷20mA
 green	 yellow	Measuring tube empty	<4mA
 red	-	Meter is out of order, service necessary	<4mA
 red	 yellow	Meter is temporarily beyond parameters	<4mA
-	-	Supply voltage error	-

Flow direction:

The arrow indicates the direction liquid flow inside the sensor and thus the correct orientation of the meter's sensor for installation in piping. In case of inversely performed installation, it is possible to switch the direction in the electronics to positive/negative through BLUETOOTH service interface.

Basic parameter settings

The meter or flow meter parameters are set by the manufacturer in accordance with the purchase order. If these values are not indicated in your purchase order, the meter will be set up using the default parameters in accordance with the meter's range.

Measuring range boundary values	Refer to meter's nameplate
Excitation time constant	Standard 140 ms
Impulse output width /gap	Adjustable (from 200 μ s)
Impulse output constant	fmax [900 Hz] => Qmax
Flow at 4mA current output	Meter minimum flow, refer to meter nameplate
Flow at 20mA current output	Meter maximum flow, refer to meter nameplate
Current loop - meter error status	<4mA
Current loop - empty tube	<4mA
Application	Stable flow

Safety rules for operator

Any interventions in the inductive flow sensor and evaluation unit itself are illegal on the part of operator and they may lead to direct scalding by medium. Perform electrical connection always after powering off.

Technical data

Power	24V DC±15 % with polarity reversal protection
Input power	4.2VA
Electrical connection	by means of M12 (8-pin) connector
Display	2× LED (meter status distinguished by 4 colours)
Construction	compact
Max. temperature of medium	90 °C (as per lining), at a higher temperature, upon agreement with manufacturer
Size	DN 4÷600
Lining material	rubber (hard, soft, for potable water): DN25÷DN600 (up to 80°C) PTFE: DN 10÷DN 80 (up to 150°C), PVDF: DN 4÷DN 20, RILSAN: DN 25÷DN 600 (up to 90°C) ETFE: DN 100÷DN 600 (up to 150 °C), PFA, Ceramics (upon agreement with the manufacturer)
Electrode material	CrNi steel DIN 1.4571, Hastelloy C4, Titanium, Tantalum
Construction	all-welded frame
Sensor material	flanged – stainless steel and structural steel with polyurethane coating sandwich, threaded, food processing – stainless steel
Process connection	sandwich (PN25 only) flanged DIN (EN1092) threaded (EN 10226-1) food processing (fittings DIN 11851, clamp)
Measure range (Qmin/Qmax)	unidirectional/bidirectional for 0.2÷12 m/s (1/60)
Flow meter accuracy	up to 0.5 % (for 0.1 ÷ 10m/s)
Repeatability	up to 0.2% (for 0.1 ÷ 10m/s)
Additional electrodes	reference grounding and detection ones for empty pipeline (DN 10÷DN 600)
Empty pipeline detection	DN 10÷DN 600
Min. medium conductivity	20µS/cm (at a lower conductivity, upon agreement with manufacturer)
Communication / Settings	by means of software connected through Bluetooth
Outputs (passive)	OUT1 - impulse (max. 1.6 kHz, selectable constant) OUT2 – impulse (imp. constant as per OUT1)/status/flow-switch Analogue 4÷20 mA, adjustable range
Sampling:	900 samples per second (standard)
I/O response:	70ms (current loop)
Max. ambient temperature	55°C
Ambient humidity:	max. 90%
Pressure	PN10, PN16, PN25, PN40
Pressure loss	negligible
Flow sensor protection	IP65, IP67, IP68
Electronics protection	IP65

If you do not find your size or structure in the Flow sensor technical parameters Table, it is a special or non-standard design. In this case, find the information on the sensor nameplate where this information is always indicated, or please contact the manufacturer for more detailed information.

Error limits at reference conditions

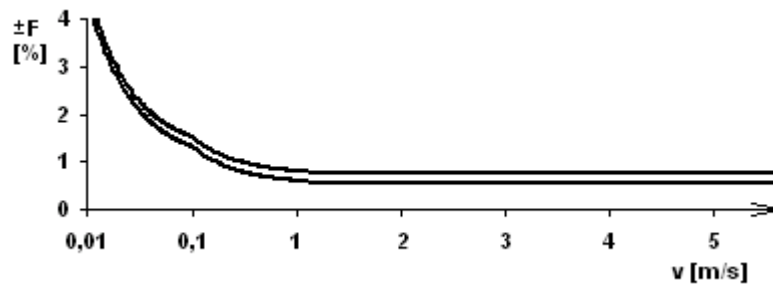

Diameter nominal	Measured value maximum error			Curve
	$v \geq 1$ m/s	$1 \text{ m/s} > v \geq 0,1$ m/s	$v < 0.1$ m/s	
DN [mm]				
\leq DN 10	0.8 % of M*	0.72 % + 0.8 mm/s	1.55 % + 0.35 mm/s	1
$>$ DN 15	0.5 % of M*	0.52 % + 0.8 mm/s	1.22 % + 0.35 mm/s	2

* Of M – of the measured value

Factory settings

The impulse output is always selected as the nearest decimal constant, satisfying the condition that the output frequency at the maximum flow for the given DN size is not higher than 800 Hz. The current loop is set in such a manner that 4 mA corresponds to zero flow and 20 mA corresponds to its maximum value. As standard, the OUT2 output is configured by factory as the failure signal.

Impulse constants and current loop – factory settings

Diameter nominal DN	Impulse output		4 – 20mA (in Qmin/Qmax 1/100 range)	
	Vout[imp/l]	Vout - pulse width [ms]	Q[l/h] for 4mA	Q[l/h] for 20mA
4	100	4	0	540
6	100	4	0	1200
8	10	4	0	2200
10	10	4	0	3 400
15	10	4	0	7 600
20	10	4	0	14 200
25	10	4	0	21 000
32	1	4	0	34 000
40	1	4	0	54 000
50	1	4	0	84 000
65	1	4	0	144 000
80	1	4	0	220 000
100	0,1	4	0	340 000
125	0,1	4	0	534 000
150	0,1	4	0	760 000
200	0,1	4	0	1 350 000
300	0,1	4	0	3 052 000
400	0,01	4	0	5 400 000
500	0,01	4	0	8 400 000
600	0,01	4	0	12 000 000
500	0,01	4	0	8 400 000
600	0,01	4	0	12 000 000

Factory configuration of outputs

OUT1 (impulse)	OUT2 (status/impulse)	Analog OUT
impulses in flow direction	status output – Failure	4-20mA in flow direction

Table with flow ranges for individual DN sizes

Diameter nominal [mm]	Qmin [m3/h] as per Qmin /Qmax		Qmax [m3/h] (12 m/s)
	1/60 (0.2 m/s)	1/100 (0.12 m/s)	
DN 4	0,01	0,006	0,6
DN 6	0,02	0,012	1,2
DN 8	0,04	0,022	2,2
DN 10	0,06	0,034	3,4
DN 15	0,13	0,076	7,6
DN 20	0,24	0,142	14,2
DN 25	0,35	0,21	21
DN 32	0,6	0,34	34
DN 40	0,9	0,54	54
DN 50	1,4	0,84	84
DN 65	2,4	1,44	144
DN 80	3,6	2,2	220
DN 100	5,6	3,4	340
DN 125	8,9	5,34	534
DN 150	13	7,6	760
DN 200	23	13,5	1350
DN 250	35	21,1	2115
DN 300	51	30	3050
DN 350	70	41	4150
DN 400	90	54	5426
DN 500	141	84	8480
DN 600	203	122	12200

Basic sensor sizes

Threaded design

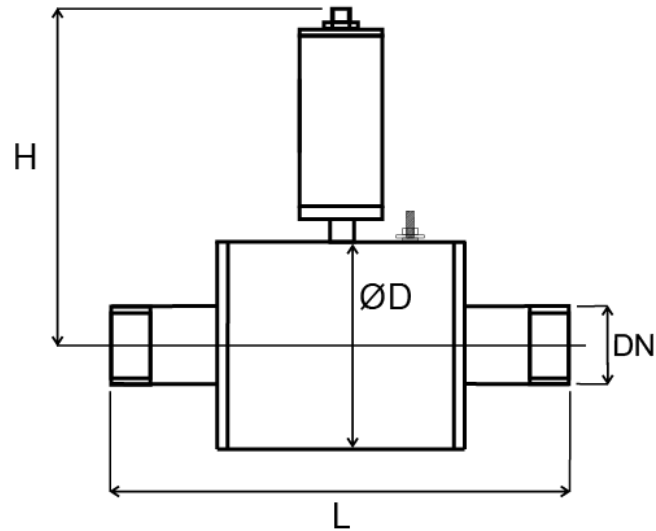

Diameter nominal [mm]	Threaded connection	D External Ø sensors	L Building length of sensor	H Building height of comp. meter	Compact flow meter weight (kg)
4	½"	70	157	150	3
6	½"	70	157	150	3
8	½"	70	127	150	3
10	¾"	70	193	150	4
15	½"	70	196	150	4
20	¾"	80	206	155	4
25	1"	90	206	160	5
32	1 ¼"	100	233	165	5
40	1 ½"	116	256	173	6
50	2"	136	261	183	7

The Table is for PN25.

Inter-flanged design

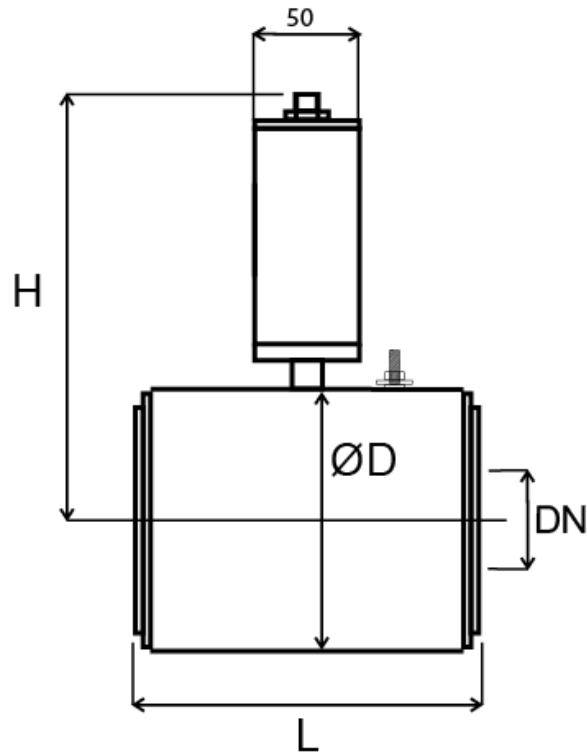

Diameter nominal [mm]	D Outside diameter of sensor	L Building length of sensor	H Building height of comp. meter	Compact flow meter weight (kg)
10*,15	51	90	188	2
20	61	90	198	2
25	71	90	208	3
32	82	90	219	3
40	92	110	229	4
50	107	110	244	4
65	127	130	264	5
80	142	130	279	6
100	168	200	305	7
125	194	200	331	9
150	224	200	361	11
200	284	200	420	14

The Table is for PN25.

** Process connection is performed through DN 15 flange*

Flanged design

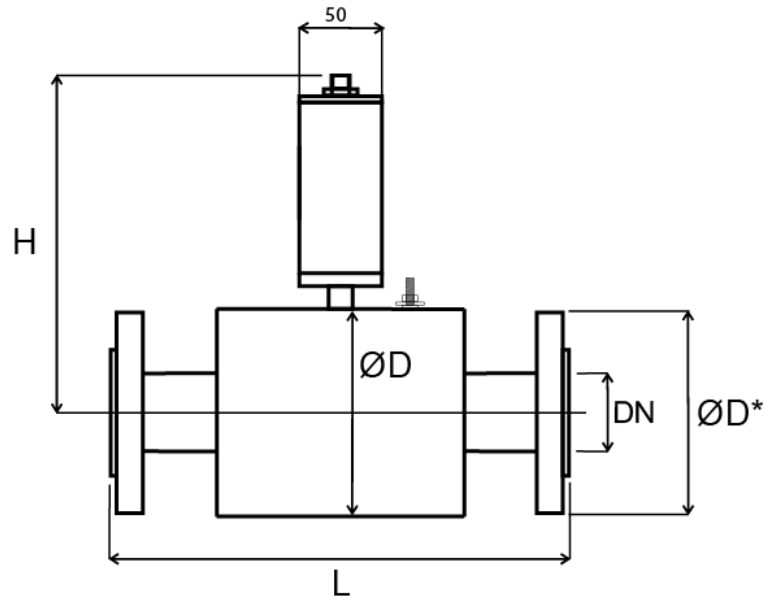

D ...The outside diameter corresponds to the required pressure class and standards.*

Diameter nominal [mm]	D Outside diameter of flanges	L Building length of sensor	H Building height of comp. meter	Compact flow meter weight (kg)
10*,15	51	200	146	4
20	61	200	146	4
25	71	200	151	5
32	82	200	156	6
40	92	200	161	7
50	107	200	169	9
65	127	200	179	11
80	142	200	186	12
100	168	250	199	19
125	194	250	212	26
150	224	300	227	37
200	284	350	257	44
250	-	450	300	65
300	-	500	325	78
350	-	550	355	88
400	-	600	385	106
500	-	600	-	160
600	-	600	-	250

The Table is up to DN 200 for PN25, DN250 and DN300 for PN16, DN350 and DN400 for PN10.

** Process connection is performed through DN 15 flange*

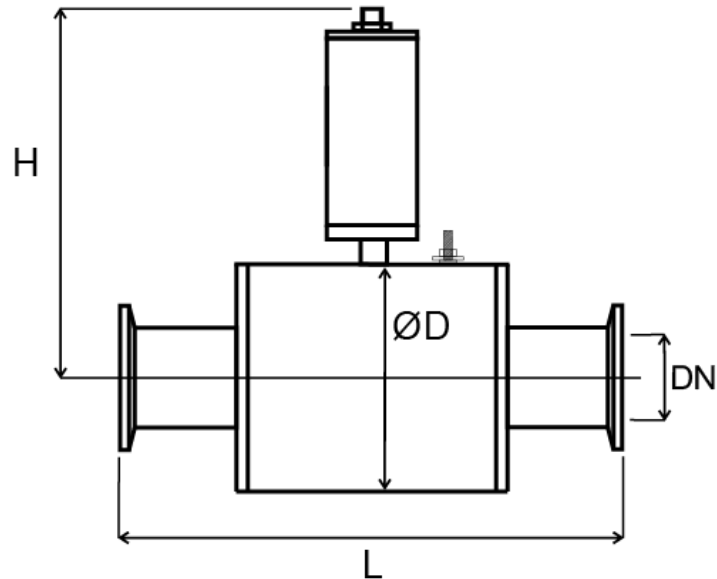

Diameter nominal [mm]	Food grade connection CLAMP/ Screwed fitting	D External Ø sensors	L Building length of CLAMP	L Building length of food grade screwed fitting DIN11851	H Building height of comp. meter	Compact flow meter weight (kg)
10	DN 10	70	189	179	150	4
15	DN 15	70	182	172	150	4
20	DN 20	80	182	176	155	4
25	DN 25	90	182	186	160	5
32	DN 32	100	189	197	165	5
40	DN 40	116	210	220	173	6
50	DN 50	136	217	231	183	7
65	DN 65	151	upon agreement	upon agreement	191	8
80	DN 80	177	upon agreement	upon agreement	204	9

The Table is for PN25.

Diameter nominal [mm]	DN 10 ÷ DN 20	DN 25 ÷ DN 40	DN 50	DN 65	DN 80
Outside dimension of CLAMP [mm]	34	50,5	64	91	106

Nomogram for quick proposal of the measured place

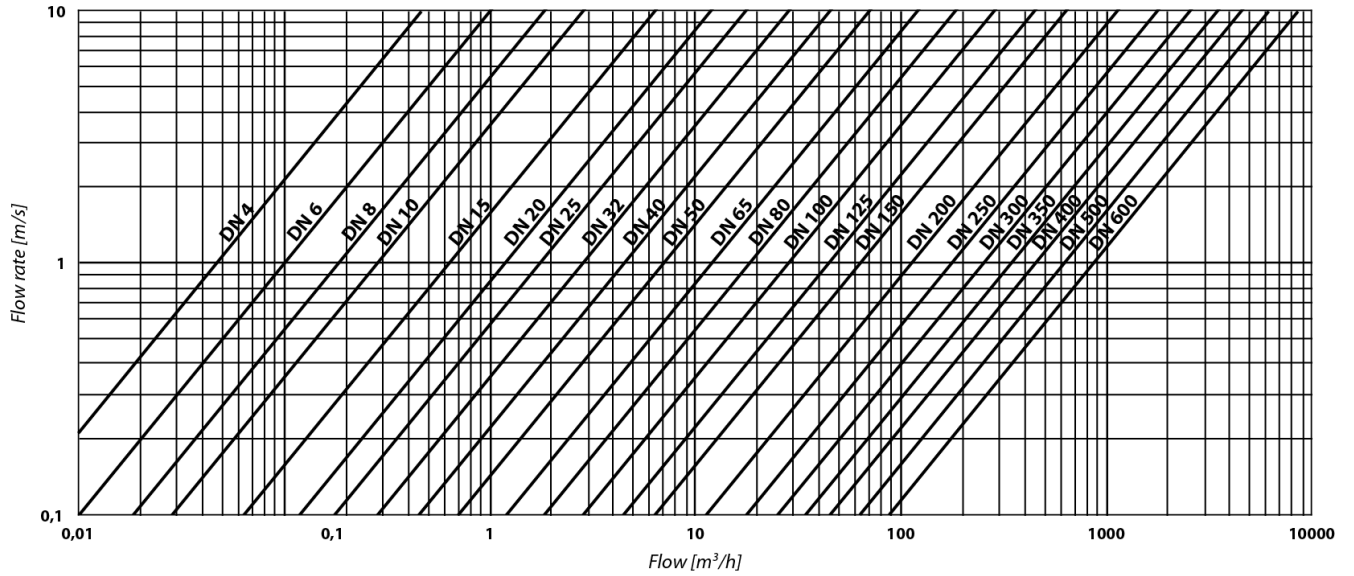

Reduction in DN pipe

If the pipe's DN is higher than that of the meter selected

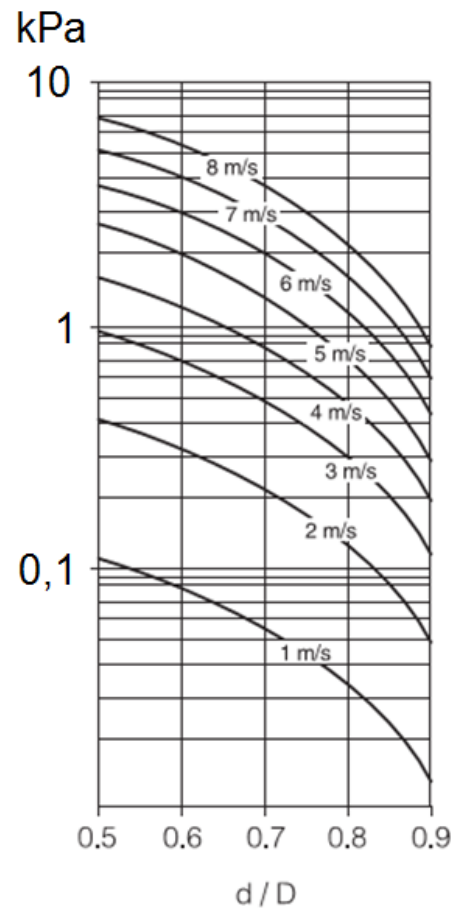
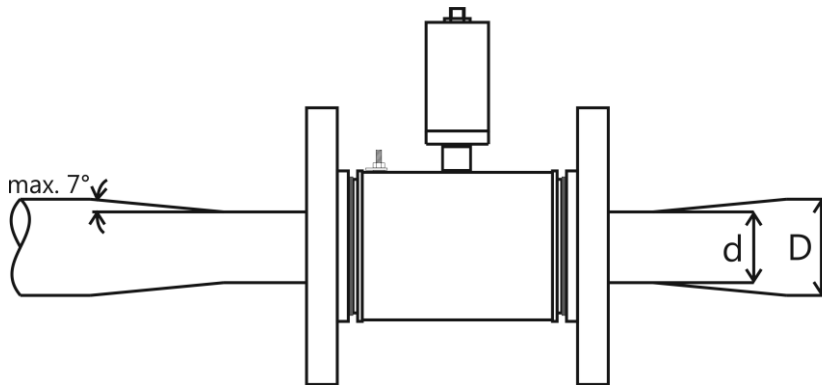

Failures and their symptoms during measurement

Unstable indications and readouts may appear due to:

- big portion of solids
- in homogeneities as a result of the state of matter
- turning point of immixture
- continuous chemical reactions in the measured fluid
- use of diaphragm pumps or plunger pumps
- poor grounding

Flow sensor cleaning

Some measured liquids contain substances and chemicals that tend to form layers inside the pipes including the measuring pipe, which may affect the measurement accuracy. In this case it is necessary to clean the flow sensor from time to time. Ceramic pipes can be cleaned mechanically with a steel brush and then the cleaning can be completed using diluted hydrochloride acid or citric acid solution. The acid removes calcareous layers or black layers of iron complex. If the contamination is greasy, it must be cleaned by caustic soda or potassium hydroxide solution. Flow sensors with teflon, plastic and rubber measuring pipe cannot be cleaned mechanically with a brush, it is only possible to clean them chemically. After cleaning, the pipe must be properly rinsed with water.

Service

All repairs within warranty and after warranty period are only conducted by the manufacturer, **COMAC CAL s. r.o.**

Order code

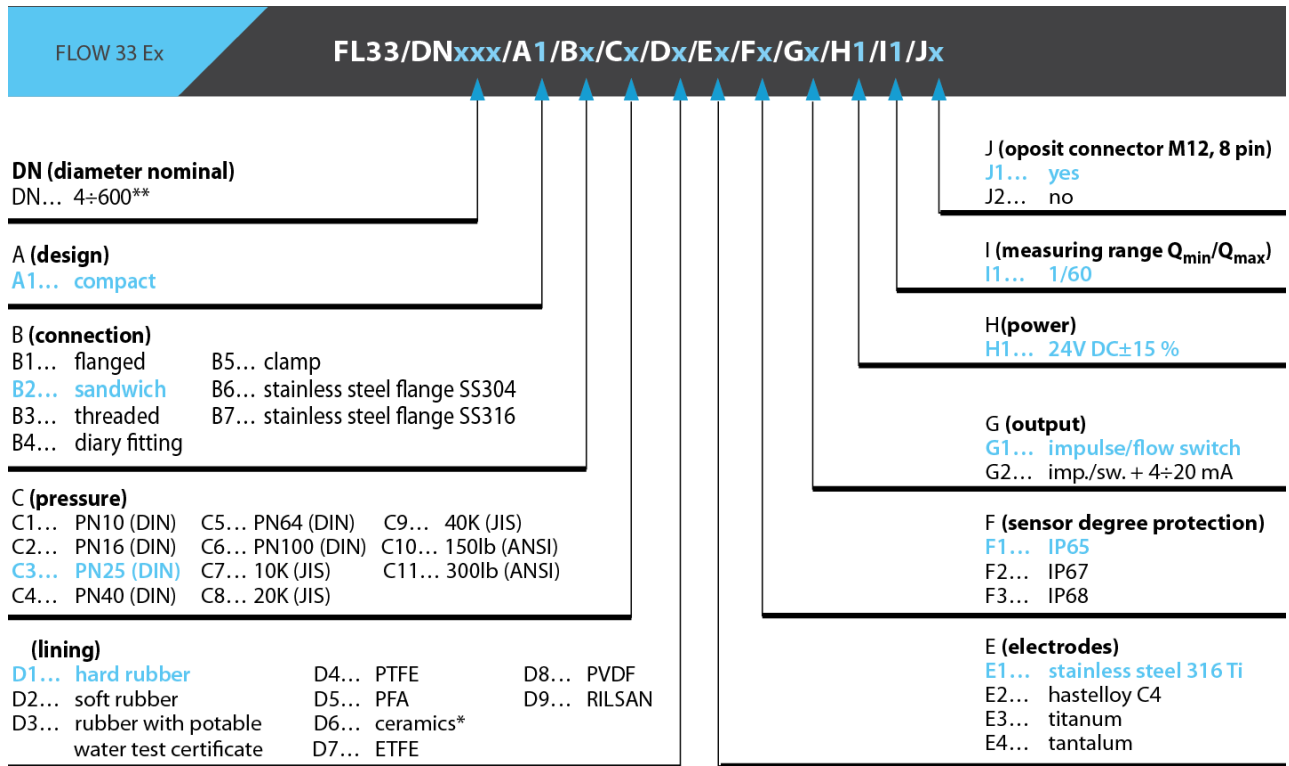

Standard set include installation manual and calibration certificate

*Upon agreement with the manufacturer.

**DN 4, 6, 8 PVDF only, accuracy 1%, flow range 1/60

Returning the meter to COMAC CAL s.r.o.

The meter you have was made with the maximum precision and it has been checked many times and wet calibrated.

If the meter is used in agreement with this manual, the occurrence of faults is very rare. Should they ever occur, contact our service department. If you return the meter to the manufacturing plant, adhere to the conditions stated below:

- Clear the meter of contaminations stuck to the sensor and measuring tube (eventually to the Evaluation Unit).
- If the meter was run with poisonous, etching, combustible liquids or with fluids dangerous to water, check it and if appropriate, flush and neutralize the cavities inside the sensor.

Please attach full description of the fault. COMAC CAL s.r.o. will not be able to process your request promptly and correctly without this form.

Supplement

FLOW 33 BT Setup

*Manual for using the setting software FLOW 33 BT Setup by
means of Bluetooth communication
(Android version)*

Basic description of the software

This software is designed for changing or controlling the FLOW 33 meter user settings. In order to use this software, both of the devices must incorporate Bluetooth communication. Bluetooth is a short-range wireless communication technology, making it possible to establish connection between devices up to a distance of approx. 8 metres. These devices are provided with the  logo. This logo is located on the nameplate of the meter.

Current software version is designed for Android operating systems only!

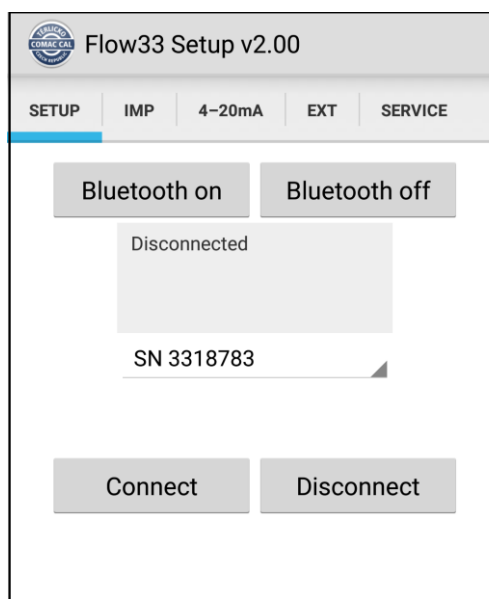

Installation takes its course in a classical manner according to the device used. After installation and launching the program, the user has individual tabs (see figure) according to associated individual parameter groups. Prior to connecting and setting, it is necessary to pair both devices in Bluetooth setup right in the device (except for FLOW 33 Setup software).

Installation of .apk package

The programs in Android OS are applications in the package with .apk suffix and the installation itself is launched from this file.

You will find the downloaded applications and you will install them using any file manager copied, e.g. to SD card. After finding the installation package FLOW33.APK, you simply "touch" the file with your finger and install it. During the first installation, the meter will inform you, most likely, that unknown sources are not permitted. It is necessary to enable them in settings (the meter will guide you) and the application is reinstalled.

The path to this option is MENU > SETTINGS > SECURITY > UNKNOWN SOURCES.

After the installation is completed, we recommend you to disable this option as you will enhance the security of your device against unwanted software.

Connection to Bluetooth devices

To launch the communication, you must be connected to your device. Activate the Bluetooth wireless module in your device (the state of Bluetooth connection is indicated by icons on System bar). If you are connecting Bluetooth to a new device (meter) for the first time, you need to pair it with your phone. Thanks to this, both devices will be configured in such a manner that they can be connected to each other safely. After that, the devices will be establishing the connection automatically.

Activation and deactivation of wireless Bluetooth module

On the desktop or on the All applications screen, touch the Phone icon  . Touch the option **Wireless connections and networks**. Move the Bluetooth switch to ON or OFF position.

Pairing your phone with a Bluetooth device

Before connecting to your meter, you need to pair it with the phone (tablet, etc.). Once you have paired the phone with your device, both devices remain paired unless you cancel their pairing (e.g. by deleting the device from the list of paired devices, etc.).

Check in section **Settings > Wireless connections and networks** if the Bluetooth module is ON.

Touch the **Bluetooth** option. The phone will find and display the identifiers of all Bluetooth devices that are available within its reach, including the meters.

If the device you wish the phone to pair with, is not displayed in the list, check if this device is ON (once the meter is powered, its visible mode is activated by default).

If the mobile device stops searching before the Bluetooth device is prepared, touch the **Search devices** option.

In the list, touch the Bluetooth identifier of the device you wish to be paired with the mobile device. Follow the instructions and complete pairing. If you are asked to enter a password, enter 1234. If pairing is successful, the phone will connect to the device.

Connection to a Bluetooth device

Once pairing with the meter is completed and you can connect to it through the installed application FLOW 33 Setup. After launching it on SETUP tab, you can perform the connection to and disconnection from the selected and paired meter.

For selection of the meter, select the serial number of the device you wish to communicate with and the meter will be connected by pressing "CONNECT". If you cannot see the serial number in menu despite its successful pairing operation, use the "Bluetooth OFF" button to switch off and after approx. 5 seconds, switch on by the "Bluetooth ON" button. The list of devices should be updated according to currently paired serial numbers.

After termination of the communication, always perform "DISCONNECT" to disconnect from the meter. If it be to the contrary, an error occurs when returning to communication with the same serial number (in which case, switch off the Bluetooth communication and switch it on again). Consequently, it is possible to select another meter and start the communication by connection "CONNECT".

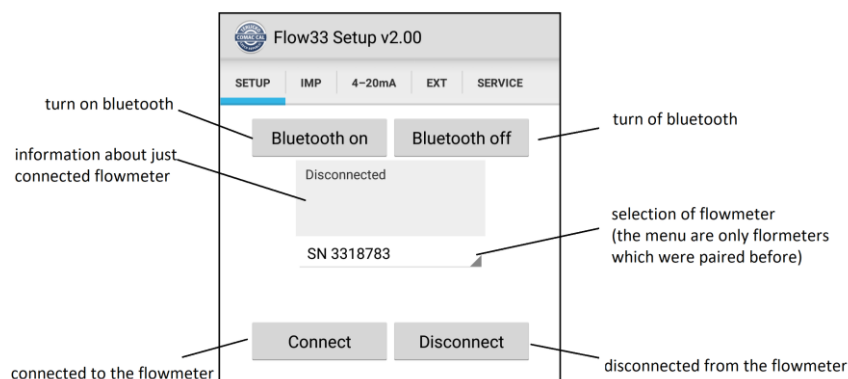

Impulse OUT1 setting

In IMP tab, the user can check or change the following settings directly:

- Configuration of impulse output OUT1
- Impulse output constant
- Selection of units for impulse constant
- Pulse width setting

And then:

- Activation/Deactivation of empty tube test
- Selection of flow direction

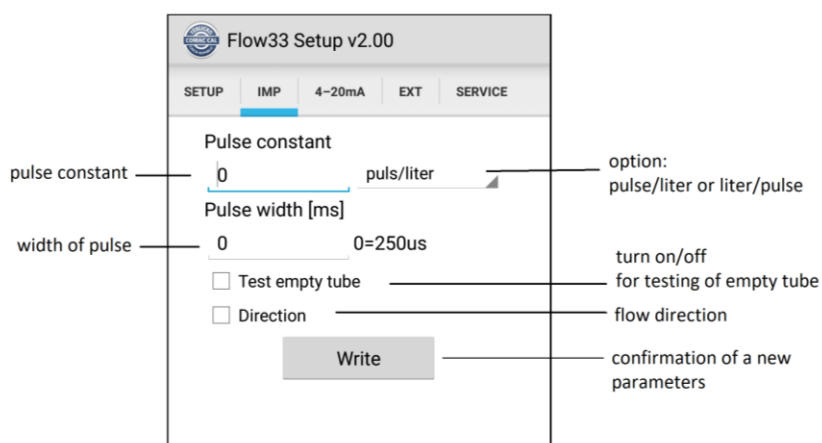

4 ÷ 20mA current output setting

In 4÷20mA menu, it is possible to set limits and perform current loop calibration if necessary.

- Configuration of values for low and high borders of analogue output for 4mA and 20mA.
- 4 and 20mA current calibration

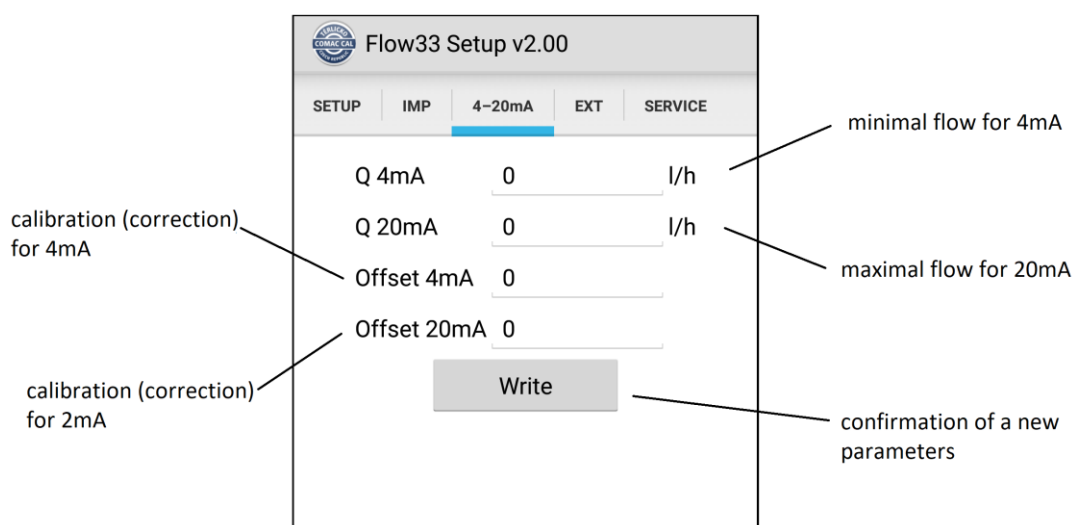

OUT2 setting

In EXT window, configuration of the expansion OUT2 output is carried out;+ the following options are available:

- Output Failure
- Impulse output (impulse output constant is then identical to the OUT1 constant)
- Flow direction
- Impulse output flow monitor function.

In case of setting the OUT2 to flow monitoring function, it is possible to change the switching point and hysteresis settings.

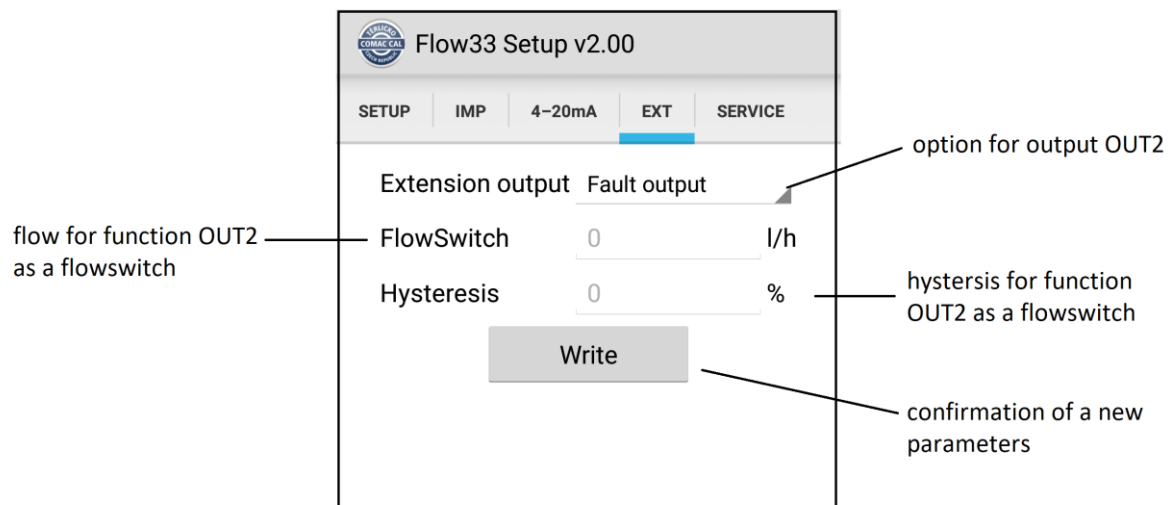

Service menu

The last tab is the SERVICE window for indication of the current flow, factory reset and possibly the activation of flow simulation. This can be used conveniently, for example, for checking the impulse transmission or analogue signal to a higher-level system.

- Activation of sending automatic service packets (of 'the current flow)
- Activation of flow simulation for testing purposes
- Factory RESET – return flow meter to factory setting (clear actual setting)

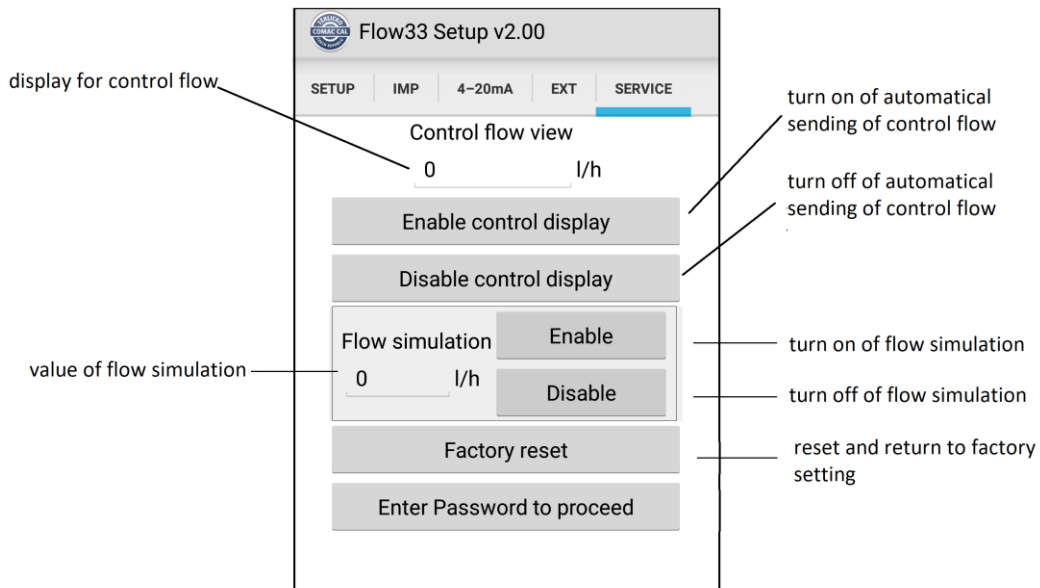

For termination of the communication, always perform "DISCONNECT" to disconnect from the meter on SETUP tab. In case of an unexpected error, for example, failure to reconnect to the meter, possibly in case of "frozen" connection, restart the meter by a short disconnection from power.

Creating a user password

The user may lock the parameter change option by creating a password in **Setup** menu using the **Enter Password to proceed** button. In this case, for activation of the **Write** button, it is always necessary to enter the password created by means of the **Enter Password to proceed** button. By default, the password in the meter is disabled

Supplement

FLOW 33XM

***Manual for using the setting software FLOW 33XM
by means of Bluetooth communication
(Windows version)***

Basic description of the program

This software program is designed for changing or checking the user settings of the FLOW 33 meter. In order to use this software program, both devices must be equipped with Bluetooth communication. Bluetooth is a technology of wireless communication over a short distance which makes it possible to establish connection between the devices over approx. 8 meters. These devices are provided with the  logo. This logo on the meter itself is found on its nameplate.

The current software version is designed for Windows operating systems only!

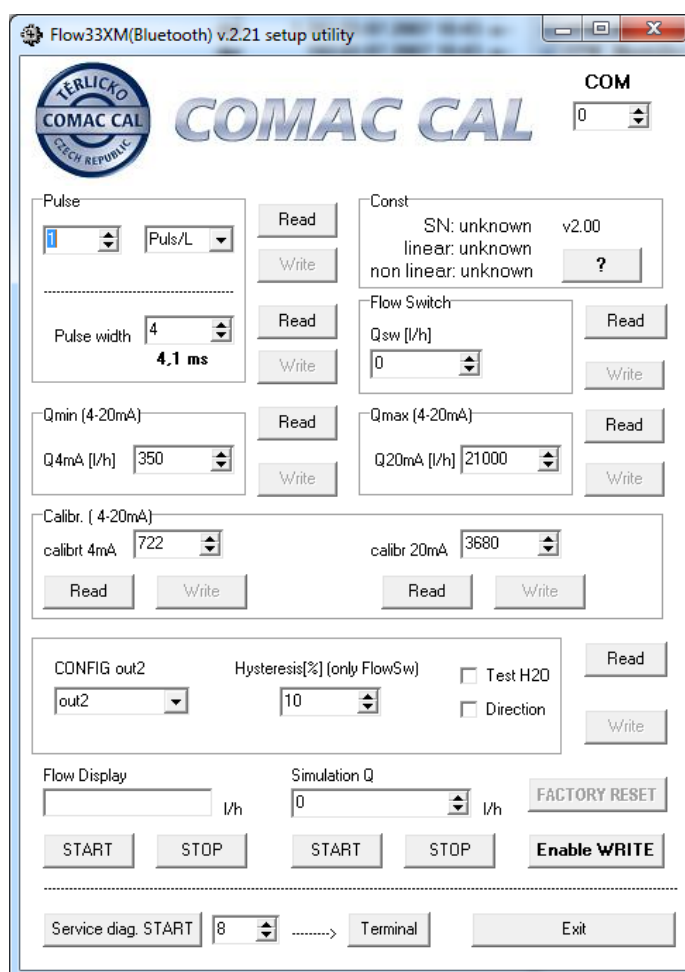

The program does not require to be installed.

Installation of Bluetooth SPP profile

The meter communicates by means of the Bluetooth SPP (serial port profile). This profile must be established by means of - Search for new Bluetooth devices. A virtual serial COM will be created for searching and entering the matching code 1234 which must be entered in the program.

Note: In some cases, Windows creates two COMs, but using the incorrect COM will result in freezing of the program. The application must be closed by pressing CTRL+ALT+DEL and the correct COM must be used afterwards.

Connecting to Bluetooth devices

After matching, connection is established automatically. Test of connection can be conducted by pressing the **?** button.

Changing parameters – Write command

To change the parameters, it is necessary to enable the **Write** button. This can be done by the **Enable WRITE** button. If changing parameters is locked by creation of the user password, you will be prompted to enter this password after pressing the button. If the password is disabled, the **WRITE** buttons are enabled without the need to enter the password. By default, the password in the meter is disabled. Before changing, it is recommended that you first read the item.

Pulse output setting

Here, the user can check or change settings directly:

- Configuration of pulse output OUT1
- Pulse output constant
- Selection of pulse constant units
- Pulse width setting

4 ÷ 20mA current output setting

In **Qmin (4÷20mA)**, **Qmax (4÷20mA)**, **Calibr (4÷20mA)** menu, it is possible to set flow rate limits and even the exact calibration of the current loop to the limit current of 4 a 20mA if necessary.

- Configuration of the high and low limit values of the analogue output for 4mA and 20mA.
- Calibration of 4 and 20mA current

Configuration of second output CONFIG out2

In **CONFIG out2** menu, it is possible to configure this output to the following options:

- Failure output
- Pulse output (the pulse output constant is then consistent with that of OUT1 output)
- Direction of flow
- Function of the flow switch output.

In the case that the **OUT2** output is set to flow switch function, it is possible to change the switching point setting (**Flow Switch – Qsw [l/h]** and **Hysteresis**).

Other functions

Test H2O and **Direction** menu items make it possible to enable/disable the measuring tube flooding test and change the direction of flow.

In **Flow Display** menu, it is possible to view the control value of the flow rate. Before reading parameters by **READ** or changing them by **WRITE**, the control view should be turned off using the **STOP** button.

For testing the connection to the superior system, it is possible to make use of the flow rate simulation in the **Simulation Q** window.

Service diag. START

The **Service diag. START** button switches the meter to diagnostic mode in which sending the text messages with diagnostic information is enabled. These messages can be captured by any terminal set to parameters 9600Bd/1Sb/no parity. The numeric parameter indicates the number of samples which can be skipped in the dump. In marginal cases, each sample can be sent – the parameter set to 1.

List of text messages:

Empty tube!	measuring tube empty
Electrode 1-interrupted!	sensing electrode 1 interrupted
Electrode 2-interrupted!	sensing electrode 2 interrupted
Signal outside measured window!	measuring signal out of parameters
Null current detect-check coil or current source!	excitation current failure
Unstable signal!	unstable (floating) signal from AD
AD value: <value>	meter OK, AD converter value