



**COMAC CAL**

**CZECH PRODUCER  
AND DEVELOPER**  
OF MEASUREMENT  
AND SENSOR TECHNOLOGY

# **FLOW 45**

Ver.3.0

*Installation and technical conditions*

**Date of issue 18/06/2019**

[WWW.COMACCAL.COM](http://WWW.COMACCAL.COM)

## Contents:

<b><i>Description of device</i></b> .....	<b>3</b>
Scope of delivery .....	3
<b><i>Storage conditions</i></b> .....	<b>4</b>
<b><i>Warranty</i></b> .....	<b>4</b>
<b><i>Installation in pipeline</i></b> .....	<b>5</b>
Important information for selection of location .....	5
Sources of disturbances .....	5
Installation examples .....	6
Actual installation in pipeline .....	7
Installation check .....	15
<b><i>Wiring</i></b> .....	<b>16</b>
Important information .....	16
Installation of the meter's detached evaluation unit .....	17
Meter wiring .....	17
Wiring check .....	18
<b><i>Putting into operation</i></b> .....	<b>19</b>
<b><i>Technical data</i></b> .....	<b>23</b>
<b><i>Factory settings</i></b> .....	<b>24</b>
<b><i>Basic sensor sizes</i></b> .....	<b>25</b>
<b><i>Nomogram for quick proposal of the measured place</i></b> .....	<b>29</b>
Reduction in DN pipe .....	29
Faults and their symptoms during measurement .....	30
<b><i>Flow sensor cleaning</i></b> .....	<b>30</b>
<b><i>Servicing</i></b> .....	<b>30</b>
<b><i>Returning the meter to COMAC CAL s.r.o.</i></b> .....	<b>31</b>
<b><i>Order code</i></b> .....	<b>31</b>

## ***Description of device***

The FLOW 45 meter is based on measurement principle by a well-known Faraday's electromagnetic induction law according to which an electric voltage is induced during the flow of a conductive liquid through the flow meter magnetic field. This is picked up by two electrodes in direct contact with the measured medium and evaluated in the electronic unit.

The FLOW 45 type of induction meters are suitable exclusively for measurement of volumetric flow of electrically conductive liquid substances with a minimum conductivity of 50  $\mu\text{S}/\text{cm}$  (at a lower conductivity, upon agreement with the manufacturer).

Meters are designed for flow measurement where the velocity of liquid is in the range of 0.2...12 m/s. The best measurement accuracy can be obtained in the range of 1...10 m/s.

## **Scope of delivery**

Accessories vary according to the variant of flow sensor and above standard optional features.

### ***Threaded design***

Electronic evaluation unit with a fixing bracket for wall mounting (not for the compact design), flow sensor (in case of compact design, the electronic unit is integral part of the flow sensor), connecting grounding cable, installation manual.

### ***Sandwich design***

Electronic evaluation unit with fixing adapter for wall mounting (not for the compact design), flow sensor (in case of compact design, the electronic unit is integral part of flow sensor), connecting grounding cable, installation manual.

### ***Flanged design***

Electronic evaluation unit with fixing adapter for wall mounting (not for the compact design), flow sensor (in case of compact design, the electronic unit is integral part of flow sensor), connecting grounding cable, installation manual.

### ***Food industry design***

Electronic evaluation unit with a fixing bracket for wall mounting (not for the compact design), flow sensor (in case of compact design, the electronic unit is integral part of the flow sensor), adapter piping connection according to DIN 11851, installation manual.

*In case of detached design, a special cable for connection of the meter (it must not be extended or cut short) is part of the flow sensor.*

### ***Storage conditions***

The temperature during transportation and storage of the meter must be within the range of -10 °C to 50 °C.

Wooden boards installed on the flanges in the factory are used for protection of lining on the flanges during storage and transportation (for PTFE lining). Remove these protective boards just before installing in the pipeline!!!

Do not lift the flanged meters by the transducer head or by the connecting box of the detached design during transportation! Use slings and place them round both process connections for transportation of meters up to DN125 (chains may damage the meter head)! Use only the metallic lugs on the flange for transportation, lifting and installation of the sensor in piping in case of DN150 and bigger!!!

### ***Warranty***

Unprofessional installation or using the induction meters (devices) may result in a loss of warranty as well as failure to comply with installation or operating conditions according to this manual.

## *Installation in pipeline*

### **Important information for selection of location**

*!!! In case of detached design, the cable must not be extended or cut short !!!*

#### *Outdoor conditions*

It is necessary to ensure that the flow sensor is not exposed to weather effects and that the measured medium cannot freeze in the flow sensor as it would damage the measuring tube.

In case of outdoor location of the electronic evaluation unit, the manufacturer recommends using a protective box or a roof to avoid direct solar exposure so that the evaluation electronics cannot get overheated.

### **Sources of disturbances**

The following items rank among the most frequent sources of disturbances to the steady flow of liquid:

- Abrupt changes in pipe cross-section if not performed as a cone with an angle of  $\alpha \leq 7^\circ$  (where  $\alpha$  is the angle made by bevelled walls of the pipe reduction).
- Incorrectly centred sealing, low ID sealing or sealing made of soft elastic materials which are pushed out into the interior pipe cross-section after flanges are tightened.
- Anything interfering in the flow of liquid, for example thermowells, branch pipes, T-pieces, bends, elbows, slide valves, cocks, flap valves, shut-off valves, control valves, butterfly valves and check valves. Pipe outlets from tanks, heat exchangers and filters.
- No intensive magnetic fields in the proximity of the induction flow sensor (detector) must be present.

**No sources of disturbances** affecting the steady flow must be present in the straight pipeline sections. They must be located in the piping after the flow sensor or at the farthest distance before it. Sources of disturbances may substantially reduce the measuring range and accuracy of the flow meters.

#### *Vibration*

We recommend supporting the connecting pipes on both sides of the meter for partial elimination of vibrations. Levels and range of vibrations must be under 2.2g in the frequency range of 20...50 Hz according to IEC 068-2-34. If the pipeline is exposed to excessive vibrations (e.g. from pumps), using compact meters is not recommended.

#### *Actual location*

The flow sensor (detector) must not be at the top position of the pipe which may be airlocked, or in declining or even in horizontal pipelines with open ends in which air may penetrate. Impurities may accumulate during long-term measurement of very low flow rates  $Q < 0.1$  m/sec. There must be a sufficient pressure in the place of flow sensor installation so that the expulsion of gas or vapour bubbles from the liquid is avoided. Little bubbles that always occur in liquids may accumulate at any of the electrodes and this may result in incorrect operation of the meter. Gas bubbles are expelled also at an abrupt pressure drop. Therefore, butterfly valves and similar elements should be located **after the flow sensor**. For the same reason, the flow sensor should not be placed at the suction side of the pump. To prevent the bubbles from accumulation at a low flow in the flow sensor, it is suitable, e.g. that the pipe is slightly ascending or that the flow sensor is located in the vertical section of the pipeline.

In the case that the sensor is equipped with an empty pipe testing electrode (3rd or 4th electrode in the upper part of the measuring tube profile), there is no risk of erroneous readout of quantity of liquid passing through the meter due to aeration of measuring electrodes.

The function of empty tube detection in horizontal mounting position operates correctly only if the evaluation unit is oriented upwards (see Fig. on right). Alternatively, it is not possible to ensure that the activation of empty tube detection in case of partly filled or empty pipes will take place.

Due to the principle, it is necessary that the maximum conductivity of medium is 6000  $\mu\text{S}$  for ensuring the functional evaluation of empty tube. Beyond this limit, errors may occur in empty tube test, and in this case, it is necessary to deactivate the empty tube test. If the conductivity of medium is beyond the permissible range, the meter may, despite the flooded system, register empty pipeline and the measurement will not start.

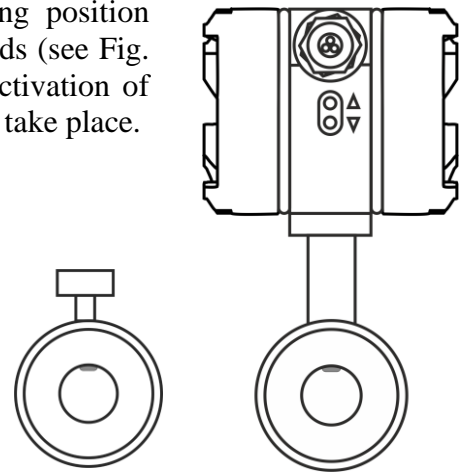

*In case of any intervention into the measuring circuit must be accessed like a pipe is fulfilled of medium, and regardless of the displayed information “empty pipe test” on the display meter !!!*

### Installation examples

Trouble-free and exact operation of the meter is dependent on its correct location in the system. The most frequent methods of the placement are shown in the following figures:

#### Recommended installation locations

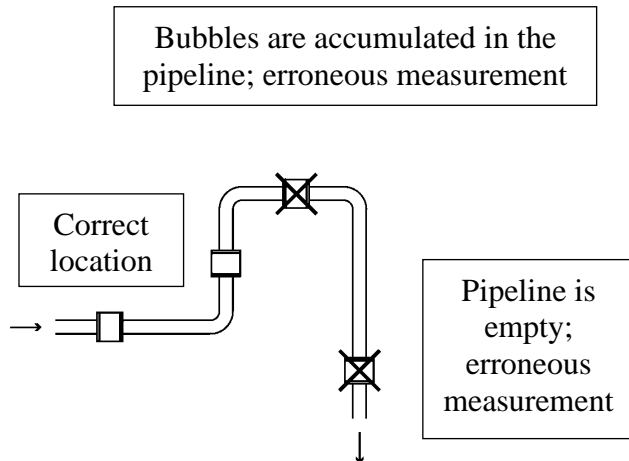

#### Downtake pipe

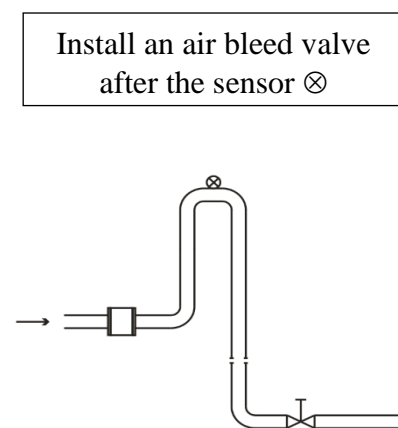

#### Horizontally laid pipeline

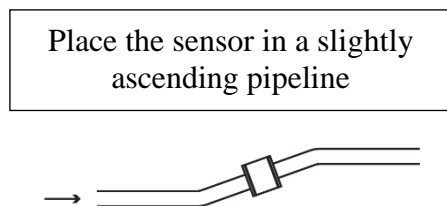

#### Long pipeline

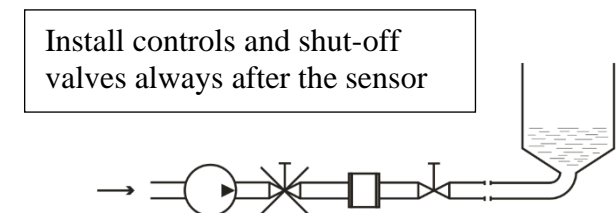

### Free inlet or outlet

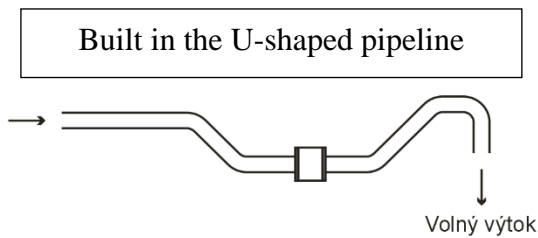

### Pumps

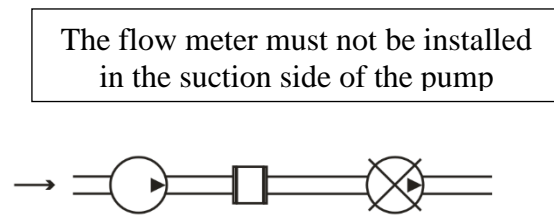

The flow of liquid flow in the flow sensor should be **steady and free of whirling**. For this reason, straight sections of pipeline with the same ID as that of the flow meter before and after the flow sensor (with permissible deviation of +5%). Recommended minimum length of straight sections is  $5 \times d$  before the flow sensor and  $3 \times d$  after the flow sensor where  $d$  is the inside diameter of the meter in millimetres. The same principles apply before and after the flow sensor in case of bi-directional flow measurement.

### Recommendations

- In case of whirled up flow, extend the calming sections of pipeline or integrate a flow conditioner.
- When blending a mixture of substances, it is necessary to install the flow meter either before the point of blending or at a sufficient distance after it ( $30 \times d$  min. where  $d$  is the inside diameter of the meter in millimetres), otherwise it will result in instability of indication.
- When plastic pipeline is used or in case of metallic pipes with internal non-conductive layer, earthing rings are needed.
- Do not install the sensor at the suction side of the pumps; this will eliminate the risk of vacuum and possible damage to the measuring tube lining.
- Pumps, bends and elbows found closely in succession in various levels should be at a distance of  $20 \times d$  at least before the flow sensor. In case of a separate elbow or bend, the placement  $10 \times d$  before the meter is recommended.
- When piston pumps, diaphragm pumps, and flexible tube pumps are used, it is necessary to install a pulse damper in the system.
- In order to provide the highest accuracy, it is important to ensure permanent flooding for the sensor (for example, by installation of the sensor in the U-shaped pipeline) even if the sensor is equipped with empty tube test. This will serve as an additional safety measure for detection of non-flooded tube.

The responsibility for suitability and adequacy of application of induction flow meters is borne by the designer or possibly the user himself.

### Actual installation in pipeline

When welding both counter-flanges to the pipelines, it is necessary to maintain their **alignment** so that levelness of bearing surfaces of the flanges onto the front faces of the detector is ensured (at the same time, this must not be achieved by unequal tightening of the bolts as there is a risk of leakage due to thermal loading in the future or the measuring tube may break during such tightening). The difference of  $L_{MAX}$  and  $L_{MIN}$  distances of the sealing surfaces of the flanges before the flow sensor is installed **must not be greater than 0.5 mm**.

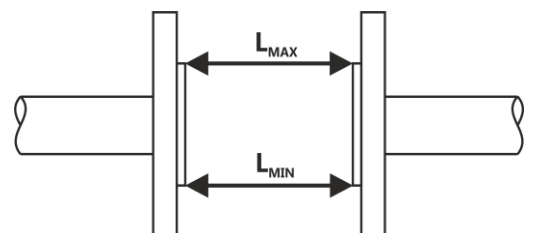

The opposition of the holes in the counter-flanges for the bolts should be ensured in the same manner and a sufficient room behind the flanges should be available for the bolts and nuts so that the actual installation of the sensor in pipeline and its attachment with the bolts is made possible.

The manufacturer recommends using an intermediate piece during welding. It is absolutely excluded to use the flow sensor as an intermediate piece due to thermal damage. The welding current must not run through the flow sensor during electrical welding. The installation of the flow sensor is carried out after welding, coating, building and similar works are completed.

The actual installation is performed by the fixation between the counter-flanges that are welded to the calming pipeline ( $5 \times d$  before and  $3 \times d$  in the direction of flow) whereas the liquid must run through the flow sensor in the direction **indicated by the arrow** on the sensor name plate.

During installation, do not lift the meter by the evaluation unit housing (in case of detached design, by the sensor terminal box), possibly under the meter's metallic housing but always use slings round the process connection or use the lifting lugs on the flanges.

#### *Installation position*

The inductive flow sensor is installed in arbitrary position in vertical piping. In case of horizontal piping, it is necessary to make sure that the sensor is installed with its measuring electrodes in horizontal position. In case of the earthing electrode design, possibly with testing for empty pipeline, then the installation is always performed with the earthing reference electrode facing down (with the sensor terminal box, eventually with the evaluation unit facing upwards). Then the earthing reference electrode is in the bottom position and the empty tube sensing electrode is in the top position of the flow sensor.

Every time when the empty tube testing electrode is not covered with a liquid for 5sec at least, the flow meter will display the "Empty tube" status, and if it is necessary, it sends out an error message and stops taking measurement. The measurement accuracy is maintained in this way. Once the electrode is covered with the liquid again, the error message disappears and the flow meter starts taking measurement again.

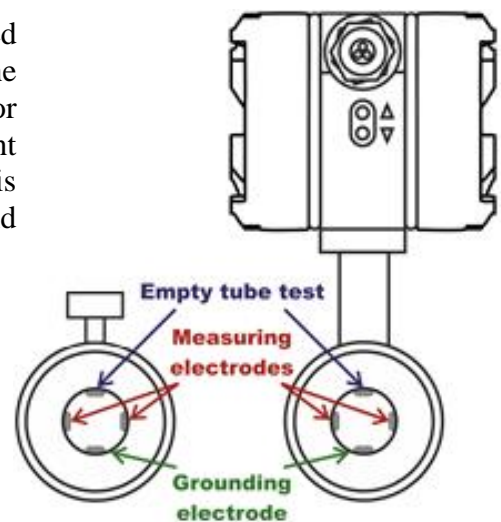



*Measurement error caused by incorrect mounting installation*

1) *correct installation (flow sensor should be install in arbitrary position in vertical piping)*

**EMPTY TEST – ON**

**EMPTY TEST – OFF**

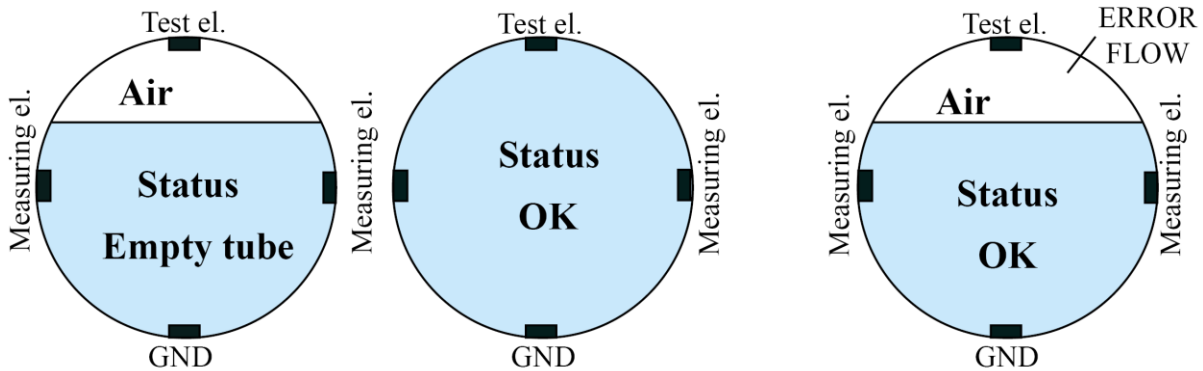

2) *incorrect installation (placing the unit diagonally, Empty test – ON)*

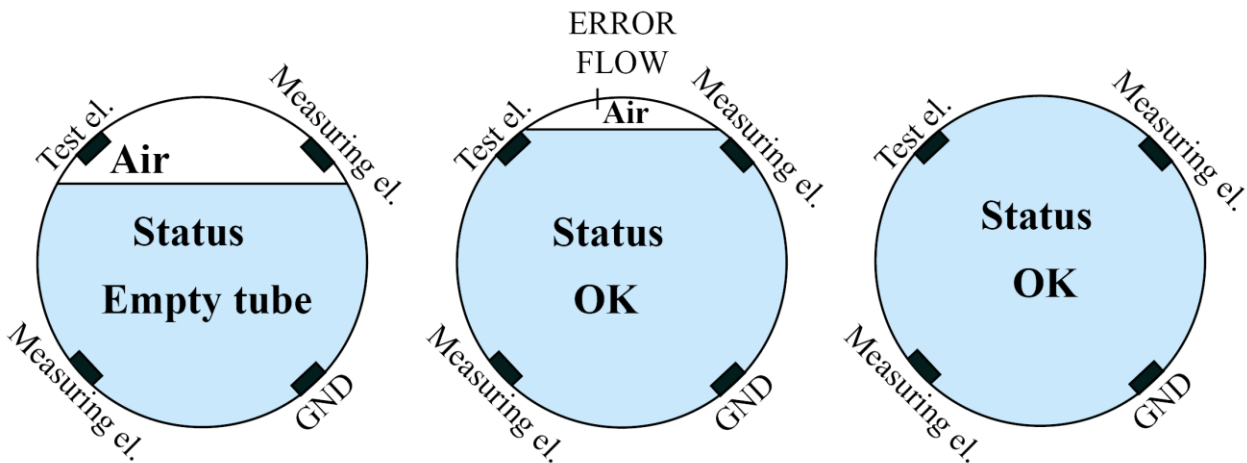

*Installation in piping and placement of measuring electrodes in flow sensor*

*Version with earthed electrode and empty piping test electrode*

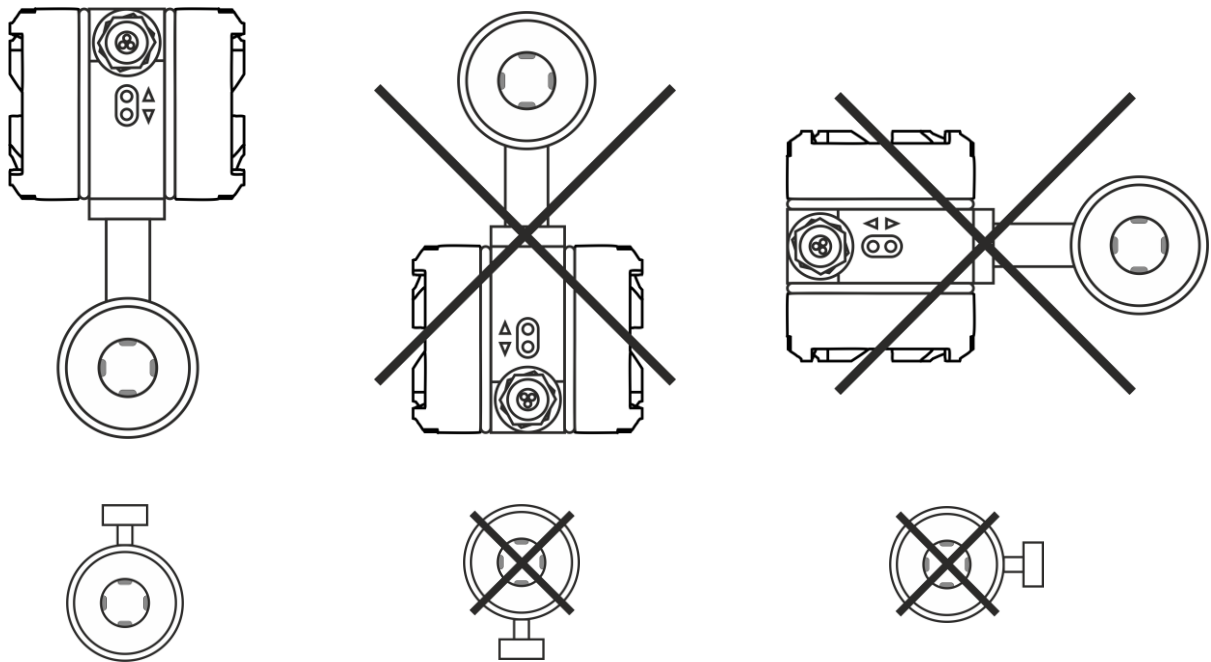

During installation, beware of:

- dropping the meter onto the ground and damaging the measuring tube or electronics
- contamination of the electrodes (do not touch the electrodes, otherwise they get contaminated)
- when additional sealing is used, avoid its interference in the flow profile of the detector between the flanges and the pipeline, otherwise the flow measurement error may be increased

*Tightening torques*

It is absolutely necessary to tighten the bolts and nuts equally by alternating sides and in the order shown in figure applying the maximum torque according to the table.

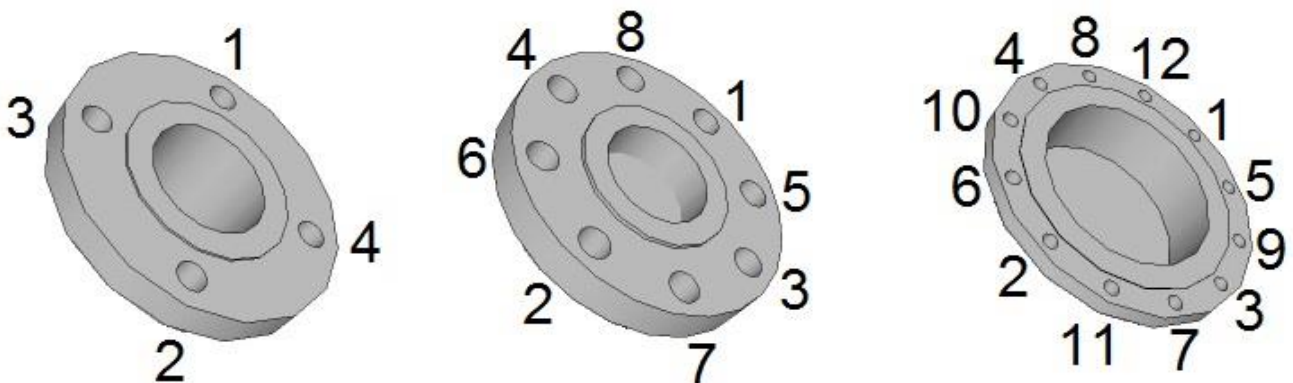

If the bolts are tightened too much during the installation of pipework components, deformation of the sealing surface may occur. In consequence, the torque values indicated in the table are used as a guidance for tightening the screws and bolts.

Table with tightening torques for screws/bolts (EN 1092):

Diameter nominal DN	PN 10			PN 16		
	Screws	Tightening torque [Nm]		Screws	Tightening torque [Nm]	
		Rubber	PTFE, PFA, ETFE, PVDF		Rubber	PTFE, PFA, ETFE, PVDF
10	4 x M12	20	25	4 x M12	20	25
15		20	25		20	25
20		20	25		20	25
25		20	25		20	25
32	4 x M16	20	25	4 x M16	20	35
40		20	25		20	35
50		20	45		20	45
65	8 x M16	20	46	8 x M16	20	46
80		20	48		20	48
100		20	50		20	50
125		20	80		20	80
150	8 x M20	24	90	8 x M20	27	90
200		25	115		12 x M20	28

Diameter nominal DN	PN 25			PN 40		
	Screws	Tightening torque [Nm]		Screws	Tightening torque [Nm]	
		Rubber	PTFE, PFA, ETFE, PVDF		Rubber	PTFE, PFA, ETFE, PVDF
10	4 x M12	25	25	4 x M12	25	25
15		25	25		25	25
20		25	25		25	25
25		25	25		25	25
32	4 x M16	25	35	4 x M16	25	40
40		25	35		35	50
50	8 x M16	35	45	8 x M16	35	60
65		35	46		45	55
80	8 x M20	40	48	8 x M20	45	60
100		40	55		50	75
125	8 x M24	50	110	8 x M24	70	120
150		57	115		75	136
200	12 x M24	68	100	12 x M27	85	145

In case of using a corundum or thermoplastic tube, the same torques apply as in case of using the PTFE tube according to the given pressure series.

Threaded connection ( EN 10226-1):

Diameter nominal DN	Process connection [inch]	Tightening torque [Nm]
10	3/8"	8
15	1/2"	10
20	3/4"	21
25	1"	31
32	1 1/4"	60
40	1 1/2"	80
50	2"	5
65	2 1/2"	6
80	3"	15
100	4"	14

If you do not find your size or structure in the Torque Table, it is a special or non-standard design. In such a case, contact the manufacturer for more detailed information.

It is necessary to do the tightening three times, whereas for the first time, to 50% of the maximum torque according to the above given Table. For the second time, to 80% and for the third time, to 100% of the maximum torque. We recommend checking the screws/bolts for tightening some 24 hours after installation of the meter.

If the flanged joint is not tight, although all of the screws are tightened closely, **these must not be tightened more** but slackened on the opposite side to the untightness and tightened on the other side. If the untightness manifests itself even after that, it is necessary to check the sealing surfaces for scratches or mechanical impurities. If the scratches or any other damage are deeper than some 15% of the thickness of the flange, it is possible to remove them using fine emery paper.

In case of the threaded connection, it is necessary to check, while tightening, the screwed connection on the sensor so that torsional displacement is avoided.

### Sealing

The turned up part of the lining does not carry out the function of sealing so it is necessary to insert the appropriate seal precisely centred between the sensor and the pipeline. If the sealing extends in some place into the flow profile, it makes whirls and reduces the measurement quality. Use the seals compatible with the liquid and 5mm thick. Do not use graphite or any other electrically conductive material to hold the sealing in place during installation. It could influence the measuring signal accuracy.

### Earthing

For reliable and correct operation of the induction sensor it is necessary to provide proper protective and working earthing. The earth line must not transmit interference voltages so the other electrical devices must not be earthed by means of this line.

The flow sensor is provided with the M5 earthing screw of stainless steel with a washer and nut for proper connection of the sensor body with both counter-flanges of the metallic pipeline. The earthing cable lug is screwed there and it should be conductively connected with the counter-flanges. On the counter-flanges, it is recommended their connection to the welded crews or into a threaded hole. Connecting under the fixing screws of the flange is not suitable as they may corrode with time and cause failures in measurement.

However, if it is not ensured that the counter-flanges are in direct contact with the measured media and they are conductive, the earthing rings must be used, refer hereinafter.

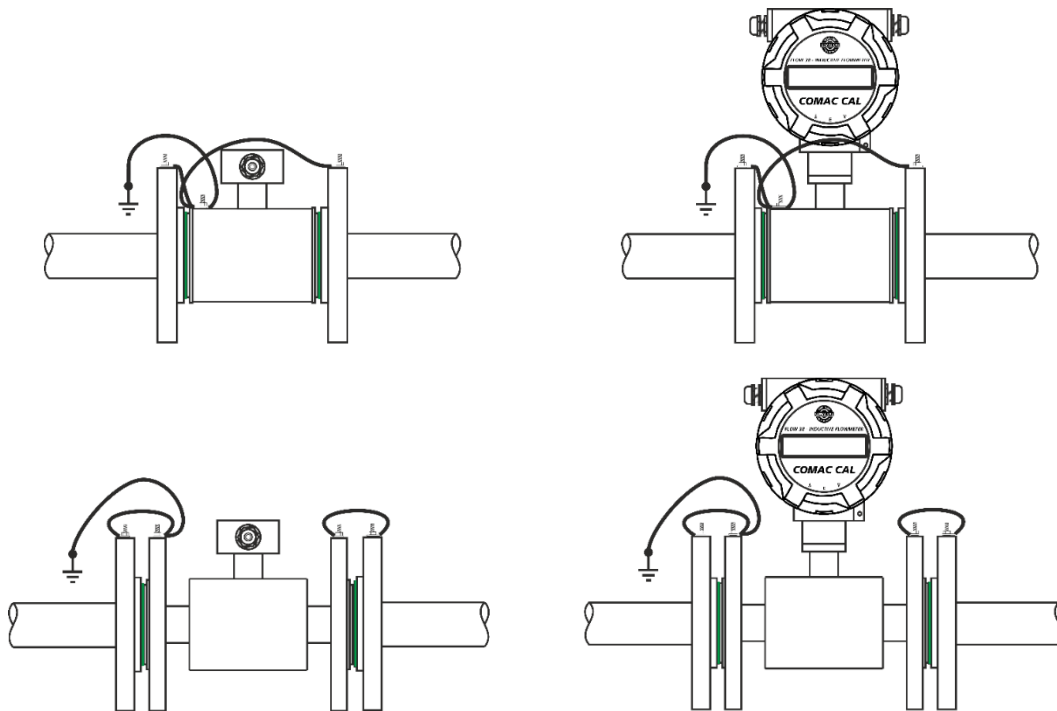

### *Earthing/grounding rings*

Using for a plastic pipeline or in case of metallic pipelines with internal plastic lining turned up or pulled out to the front faces of the pipeline flanges. Conductive earthing rings of stainless steel create conductive connection with the measured substance. Usually, potential equalization is carried out by means of the reference earthing electrode in the measuring tube. In exceptional cases, the equalizing currents may run through the reference electrode based on the device earthing conception. This may lead to deterioration of the sensor, e.g. by electrochemical disintegration of the electrodes. In such cases, it is **necessary** to use the earthing rings for potential equalization. This holds true for two-phase or two-component flows in which the medium is blended badly or its components cannot be blended. In general it can be said that using the earthing rings is always the protection against stray currents and the warranty of correct measurement at the same time.

The flow sensor is provided with the earthing screw of stainless steel for the earthing cable supplied with the mounting accessories. Then this cable must be conductively connected with the earthing rings.

The earthing rings are not part of our standard package and must be ordered separately. Chemical durability of the material must correspond with the liquid to be measured; it is usually made of the same material as the sensor electrodes. While mounting, it is necessary to insert seals in both sides of the earthing ring and take care that no part extends to the internal profile of the sensor (whirling and turbulence of the medium).

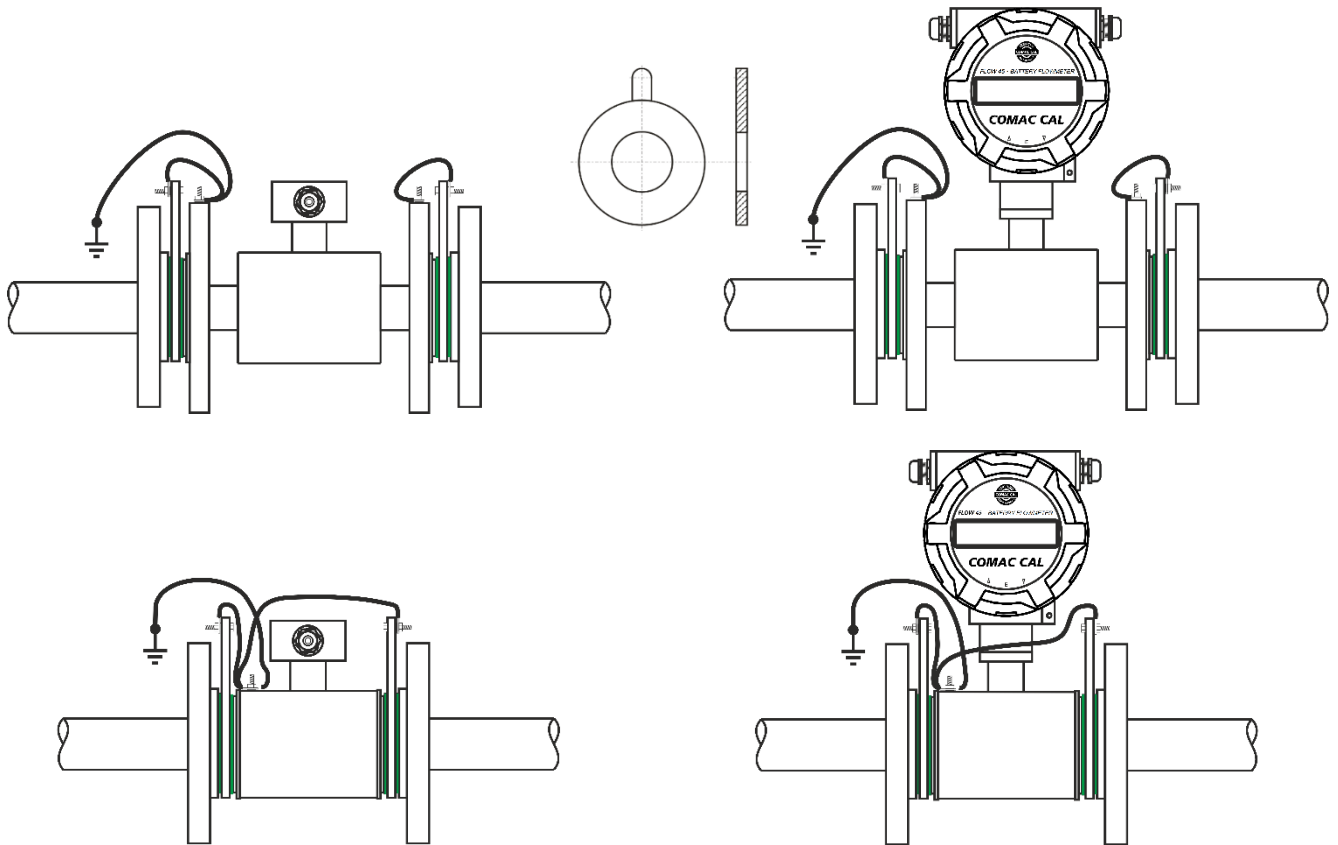

### *Electrodes*

The electrode material must be selected according to chemical resistance to the liquid to be measured. The purity of the electrodes may have an influence on measurement accuracy, their heavy foulness may cause even the interruption of the measuring function (isolation from the liquid). It is not necessary to clean the electrodes right after delivery before their installation in the pipeline. If the electrodes indicate signs of foulness, clean them with a soft cloth or use a chemical cleaning agent. Mind damaging to the lining! During routine operation, in case of a great majority of liquids, it is not necessary to clean the flow meter for the entire operation period of the flow sensor; self-cleaning by flow of the liquid is sufficient (recommended velocity is over 2 m/sec).

### *PTFE, PFA, ETFE, PVDF lining*

Meters with PTFE lining are equipped with protective covers to prevent the sealing surfaces from damaging during transportation or storage and from changing the shape (due to elastic memory of the PTFE material, it is restraightened to the tube). Protective covers may be removed only right before the installation. If these covers are removed due to a check, it is necessary to replace them immediately. Carry out the installation at the lowest point of the pipeline to avoid the occurrence of vacuum. Never detach and damage the rim of the PTFE lining turned up to the of flow sensor faces. Remove the covers from the inlet and outlet sides right before insertion of the sensor between the pipeline flanges and replace them with metal plates (0.3...0.6 mm thick). After insertion of the sensor, remove the metal plates and install the screws/bolts.

### *High temperature pipeline*

#### *High temperature medium*

At temperatures of the medium to be measured over 100°C, it is necessary to compensate the forces caused by thermal expansion of the pipeline due to its temperature rise. For short pipelines, it is necessary to use flexible seals, for long pipelines, use flexible pipe elements (e.g. bends).

The flow sensor must never be thermally insulated. In case that the sensor is placed in a thermally insulated pipeline, the thermal insulation must be interrupted and the flow sensor is installed without thermal insulation.

When a compact meter is used (evaluation unit placed on the sensor body), it is necessary to respect the temperature of medium up to 90 °C. In case of exceeding this temperature, the correct functionality of the electronic evaluation unit is not guaranteed, or there is a risk of its destruction.

### **Installation check**

After installation of the flow sensor in the pipeline, the following must be checked:

- According to the name plate, if there is a relevant meter in the given measuring point (pressure, temperature, dimension, etc.).
- If the direction of the arrow on the device is in agreement with the direction of the flow in the pipeline.
- Correct position of the measuring electrodes (horizontally).
- Correct position of the electrode for empty pipeline detection (up).
- If all bolts (screws) are tightened properly.
- If earthing rings are used, then their correct installation and connection with the sensor.
- Accuracy of flow sensor earthing.
- Accuracy of execution of the pipeline calming section lengths
- If the sensor is protected against vibrations and mechanical damage.
- If the name plate (serial number) on the sensor corresponds to the one on the electronics.

## ***Wiring***

*Workers performing wiring are subject to the requirements of Decree No. 50/1978 Coll. on activities on electrical equipment!!! When the operations described below are performed unprofessionally, the claim on warranty becomes extinct!!! Prior to any opening of the evaluation unit, switch off the power!!! It is necessary to bear in mind that in case of detached design, the electronic evaluation unit and the flow sensor form an integral unit which is calibrated and matched uniquely. In consequence, make sure that **the serial numbers of both parts are always identical!!!***

### **Important information**

#### *Flow sensor connecting cable*

The signal cable of the detached induction flow sensor cannot be led in parallel (even partly) with the cables for power distribution voltage or in the proximity to electric motors, electromagnets, contactors, frequency converters and similar sources of electromagnetic interference. In unavoidable situations, it is necessary to put the cable in an earthed iron tube.

In case of detached designs, it is possible to interconnect only the sensor and the transducer with the same serial numbers. The special cable for connection of the detached meter design must not be extended or cut short. In case of infringement of these requirements, measurement failures and significant inaccuracies may occur once the meters are connected.

For securing the tightness of the evaluation unit cover, it is necessary to keep the seal intact and clean (replace the damaged seal immediately). If the holes for cable entries are not occupied, it is necessary to do it.

#### *Evaluation unit*

As standard, the evaluation unit is delivered with batteries and starts measure automatically after installation in pipe with medium.

#### *Power battery pack*

FLOW 45 is equipped with a battery power pack. When the voltage drops below the set limit, LOWBAT will be displayed on the display. The display of this sign indicates that a battery replacement request. The manufacturer strongly recommends using only original spare parts including replacement batteries. This is the only way to prevent any damages or even destruction of the flowmeter.



## Installation of the meter's detached evaluation unit

*The design HEAD (H) – it is a standard design with a possibility of installation both in compact and detached designs (as per purchase order)*

Firstly decide if you want to install the fixing bracket behind, or under the electronics (the bracket with holes upward or downward). Install the fixing bracket on the meter's aluminium housing; place the unit as required on the wall or on a structure and mark the holes in this position for the attachment of the bracket. Unscrew the bracket and attach it to the marked location, e.g. using wall plugs and screws. Screw down the electronics on to the fixing bracket and connect the sensor cable using the connector. Attach the cable to the wall or to the structure so that it does not "dangle" from the connector. Make a "drip loop" downwards so that water cannot trickle onto the connector. Fix the conductors for power and the outputs in a similar way. After installation of all cables, turn the electronics to the required position and fix the unit to the bracket by tightening the fastening nut.

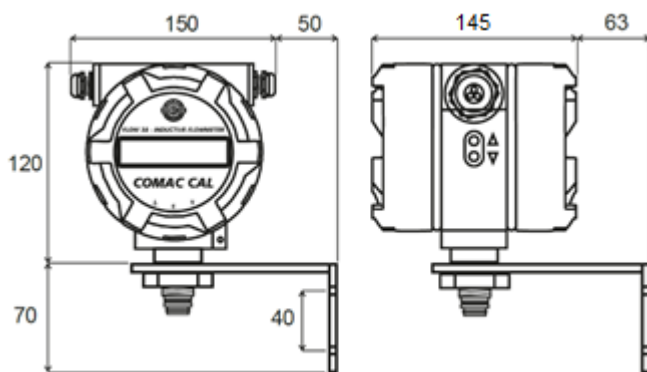

## Meter wiring

F45 is equipped by two connectors M12 (8pin a 4pin) for wiring of outputs or eventual powering from external power source.

*Description of connection of M12-8pin: output RS485 and OUT consist unipolar tranzistors.*

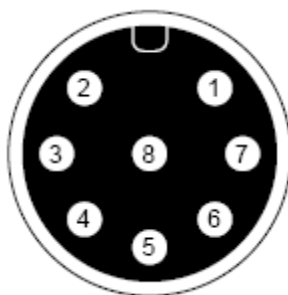

- 1 mpOUT Drain
- 2 ImpOUT Source
- 3 Empty
- 4 Empty
- 5 Empty
- 6 RS485 A+
- 7 RS485 B-
- 8 Empty

*Standard connection of cable on connector M12, 8pin opposite part of sensor:*

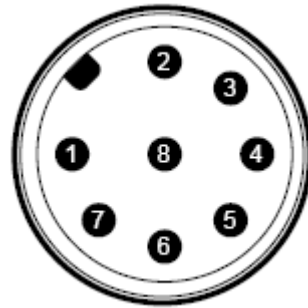

*Description of connector M12-5pin:*



- 1 +12V (external powering)
- 2 Txd (original Comacal GSM or GPRS)
- 3 -12V (external powering)
- 4 Rxd (original Comacal GSM or GPRS)
- 5 Pin (original Comacal GSM or GPRS)

*Standard connection of cable on connector M12, 4pin opposite part of sensor:*

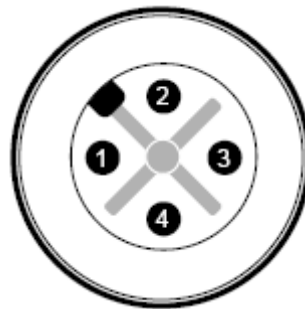

### **Wiring check**

After completion of wiring, it is necessary to check:

- Connecting cables for damage.
- If the cables used are suitable for given cable entries.
- Cables for pull relief.
- Correct tightening of cable entries.
- After the meter is closed, tighten the covers properly to the O-rings.

## ***Putting into operation***

### *Sensor status:*

It is displayed continuously on the screen as one of the menu items, different arrows on display. It can be following:

- |               |                                           |
|---------------|-------------------------------------------|
| 1) LOWBAT     | it is necessary to change the battery     |
| 2) Empty tube | empty tube (not 100% full pipe of medium) |
| 3) SD card    | SD card is inserted in sensor             |

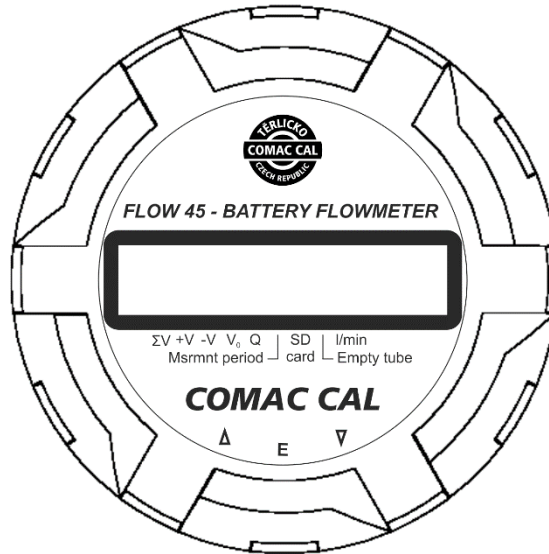

*If you wish the meter to take measurement as precisely as possible right after powering up, it is a good idea to fill the flow sensor with water, one or two days before its installation, so that all of its electrodes are flooded. Just before the installation, the water is discharged and the sensor is installed into piping. Right after installation, piping is filled with a medium so that the electrodes cannot dry off.*

### *Flow direction:*

*The arrow indicates the direction liquid flow inside the sensor and thus the correct orientation of the meter's sensor for installation in piping.*

### *Basic parameter settings*

The meter or flow meter parameters are set by the manufacturer in accordance with the purchase order. If these values are not indicated in your purchase order, the meter will be set up using the default parameters in accordance with the DN. The operator can make modifications of settings by INI file saved on SD card or by micro USB connected to PC.

### *Safety rules for operator*

Any interventions in the inductive flow sensor and evaluation unit itself are illegal on the part of operator and they may lead to direct scalding by medium. Perform electrical connection always after powering off.

## ***FLOW 45 OPERATING INSTRUCTIONS***

The meter is provided with two external buttons on the side of the electronics housing which are using for rolling of menu.

*Menu items:*

*Measuring values:*

Total flow	$\Sigma V$
Flow in positive dirrection (same like arrow on label)	+ V
Flow in negative dirrection (opposite to arrow on label)	- V
Total user flow (resetable) only in positive dirrection	r V
Actual flow	Q
Measuring periode	Msrmnt period [sec]
Year, month, day	
Hour, minute	



*Setting :*



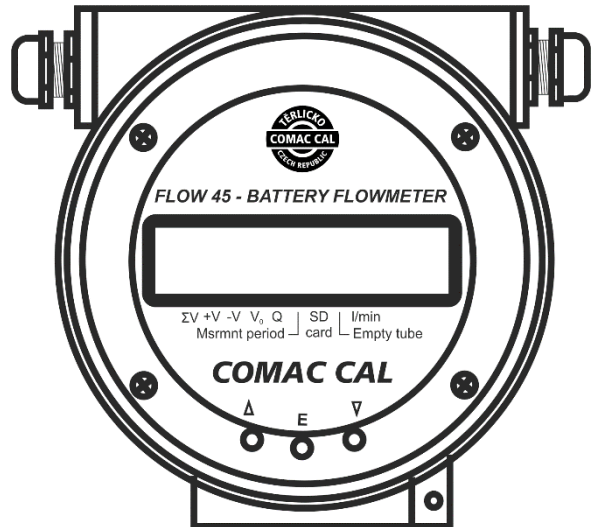







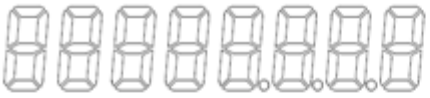













Seriál number  
 DN  
 Running time [days]  
 Pulse constant  
 Width of pulse  
 Communication address  
 Baud rate  
 Start of measuring – starting flow  
 Damping - flow averaging  
 Calibration constant k  
 Calibration konstant n  
 Writting interval on SD card



Measured values are noted by the bottom on the display.

On bottom is signalization of insertion of SD card and empty pipe testing.

The meter setting is identifiable by the following symbols:

	SN
	
	DN
	
	running time (days)
	
	pulse constant (L/imp)
	
	pulse width (ms)
	
	address
	
	baud rate
	
	starting measurement Qmin
	
	damping
	
	calibration constant C
	
	calibration constant n
	
	writing on SD card
	

Setting up the flowmeter is done via the PC via the built-in USB interface or you can load the meter's configuration from the SD card.

If you decide to use the configuration settings from an SD card, format the SD card to the FAT32 file system. Set the size of "cluster size" to 512B and create "SETUP.INI" file.

Example "SETUP.INI" file:

```
UnitQ=0
//units of flow 0=m3/h, 1=l/min
PointV=3
// number of decimal places on the counter of volume
Periode=1
//measuring periode [sec]
ImpOut=1
//pulse constant [litr/impuls]
PulseW=2
//pulse width [ms]
Address=1
//communication address RS485 a 3.3V USART
Logger=60
//writing interval [min] for function DATALOGER
```

The above file system FAT32 must also be set for the "logger" function.

To activate the inserted SD card, remove the top cover and press the triple of all internal buttons located at the bottom of the flowmeter.

## *Technical data*

### *Evaluation electronics technical parameters*

Supply voltage:	Inserting lithium battery pack
Display:	one line alphanumeric LCD
Size	DN 10...200
Lining material	rubber (hard, soft, certif. for potable water): DN25...200 (up to 70°C) PTFE: DN 10...DN 80 (T <sub>max</sub> 150°C for separate version) Rilsan: DN 25...DN 200 (T <sub>max</sub> 70°C for separate version) EFTE: DN 100...DN 200 (T <sub>max</sub> 150 °C), PFA, Ceramics (upon agreement with the manufacturer)
electrode material	CrNi steel DIN 1.4571, Hastelloy C4, Titanium, Tantalum
Construction	All-welded frame
Sensor material	flanged – stainless steel and structural steel with polyurethane coating sandwich, threaded, food processing – stainless steel
Process connection	sandwich flanged DIN (EN1092) threaded (EN 10226-1) food processing (fittings DIN 11851, clamp)
Measuring range (Qmin/Qmax)	0,2...12 m/s (1/60)
Measuring periode	user setting 1 – 60 seconds
Flow meter accuracy	1% pro 1 ÷ 10 m/s
Repeatability	up to 0.2 % (for 0.1 ÷ 10 m/s)
Additional electrodes	reference, earthing and detection for empty pipeline (DN 10...DN 200)
Empty pipeline detection	DN 10...DN 200
Min. conductivity of medium	50 µS/cm
Displayed values:	flow – m <sup>3</sup> /h; L/h; L/min with mark + or - volume – m <sup>3</sup> ; positive, negative, resettable(user counter)
Controls	2× external button (value viewing) 3× internal button (viewing + parameter modification)
Inputs:	User counter reset (according to JUMPER on power supply PCB)
Outputs	M12 – 4p (External powering, UART) M12 – 8p (ImpOut, RS485)
Archiv:	MicroSD card
Type of electronics	Head H – standard
Design	compact, detached (standard cable length 3 m)
Pressure loss	negligible
Pressure	PN10, PN16, PN25, PN40
Ambient temperature	5...55°C
Ambient humidity	max. 90%
Head size	144 x 151 x 145 mm (H x W x D), φ head 104 mm
Weight	1790 g (evaluation unit in detached version)
Material	Al cast – powder coating
Max. ambient temperature	55 °C
Flow sensor protection	IP65 (standard)
Operating	buttons inside – ▲ a ▼ Buttons outside – ▲, <b>E</b> , ▼



If you do not find your size or structure in the Flow sensor technical parameters Table, it is a special or non-standard design. In this case, find the information on the sensor nameplate where this information is always indicated, or please contact the manufacturer for more detailed information.

*Error limits at reference conditions (range 1:100)*

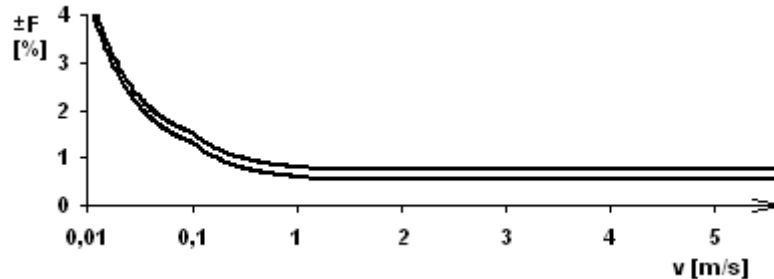

Diameter nominal	Measured value maximum error			Curve
	v ≥ 1 m/s	1 m/s > v ≥ 0.1 m/s	v < 0.1 m/s	
DN [mm]	v ≥ 1 m/s	1 m/s > v ≥ 0.1 m/s	v < 0.1 m/s	
≤ DN 10	0,9 % z M*	0,82 % + 0,8 mm/s	1,27 % + 0,35 mm/s	1
≥ DN 15	0.6 % of M*	0.52 % + 0.8 mm/s	0.97 % + 0.35 mm/s	2

\* Of M – of the measured value

### *Factory settings*

Diameter nominal	Resolution V	Resolution Q
DN ≤ 15	V [0.001 m <sup>3</sup> ]	Q [0.001 m <sup>3</sup> /h]
50 ≥ DN > 15	V [0.01 m <sup>3</sup> ]	Q [0.01 m <sup>3</sup> /h]
DN > 50	V [0.1 m <sup>3</sup> ]	Q [0.1 m <sup>3</sup> /h]

Diameter nominal [mm]	Qmin [m <sup>3</sup> /h]	Qmax [m <sup>3</sup> /h]
	1/60 (0.2 m/s)	(12 m/s)
DN 10	0.06	3.4
DN 15	0.13	7.6
DN 20	0.24	14.2
DN 25	0.35	21
DN 32	0.6	34
DN 40	0.9	54
DN 50	1.4	84
DN 65	2.4	144
DN 80	3.6	220
DN 100	5.6	340
DN 125	8.9	534
DN 150	13	760
DN 200	23	1350



## Basic sensor sizes

### Threaded design

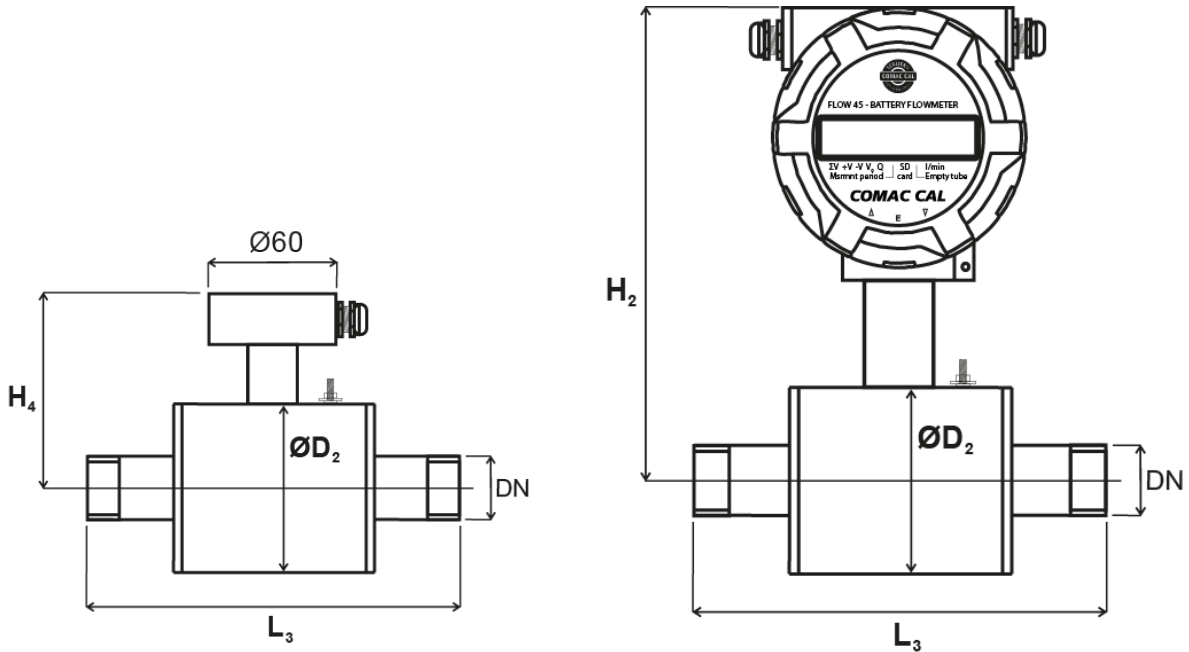

Diameter nominal [mm]	Threaded connection	D <sub>2</sub> Outside diameter of sensor	L <sub>3</sub> Building length of sensor	H <sub>4</sub> Building height of sensor	Weight of detached flow sensor (kg)	H <sub>2</sub> Building height of comp. meter	Compact flow meter weight (kg)
10	3/8"	70	186	90	4	177	5
15	1/2"	70	190	90	4	177	5
20	3/4"	80	200	95	4	182	5
25	1"	90	200	100	5	187	6
32	1 1/4"	100	228	105	5	192	6
40	1 1/2"	116	248	113	6	200	7
50	2"	136	258	123	6	210	7

The Table is for PN25.

*Inter-flanged design*

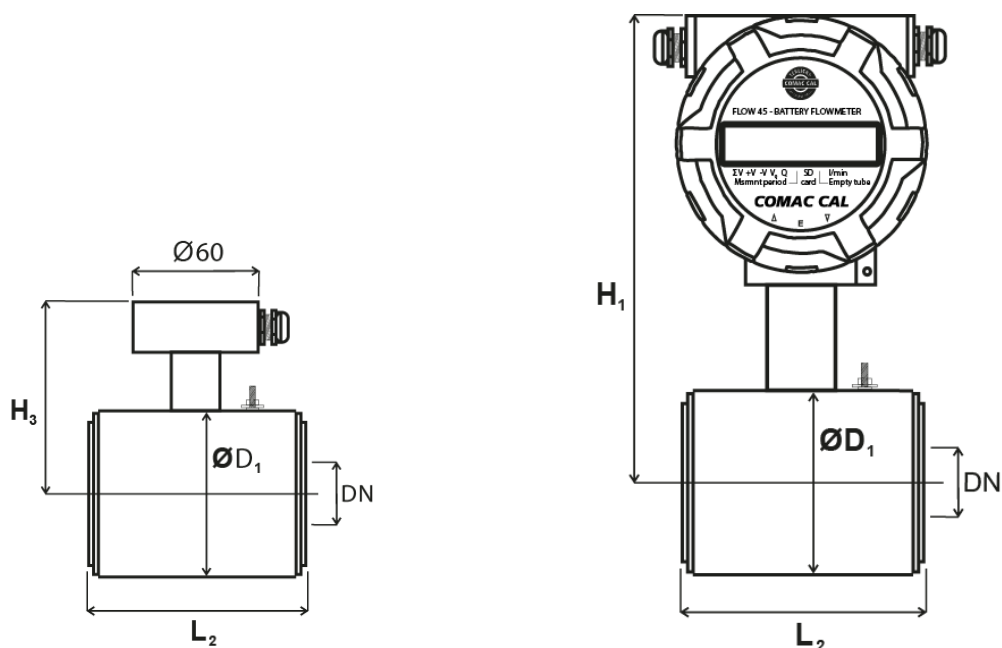

Diameter nominal [mm]	D <sub>1</sub> Outside diameter of sensor	L <sub>2</sub> Building length of sensor	H <sub>3</sub> Building height of sensor	Weight of detached flow sensor (kg)	H <sub>1</sub> Building height of comp. meter	Compact flow meter weight (kg)
10	51	90	86	2	173	3
15	51	90	86	2	173	3
20	61	90	86	2	173	3
25	71	90	91	3	178	4
32	82	90	96	3	183	4
40	92	110	101	4	188	5
50	107	110	109	4	196	5
65	127	130	119	5	206	6
80	142	130	126	6	213	7
100	168	200	139	7	226	8
125	194	200	152	9	239	10
150	224	200	167	11	254	12
200	284	200	197	14	284	15

*The Table is for PN25.*

Flanged design

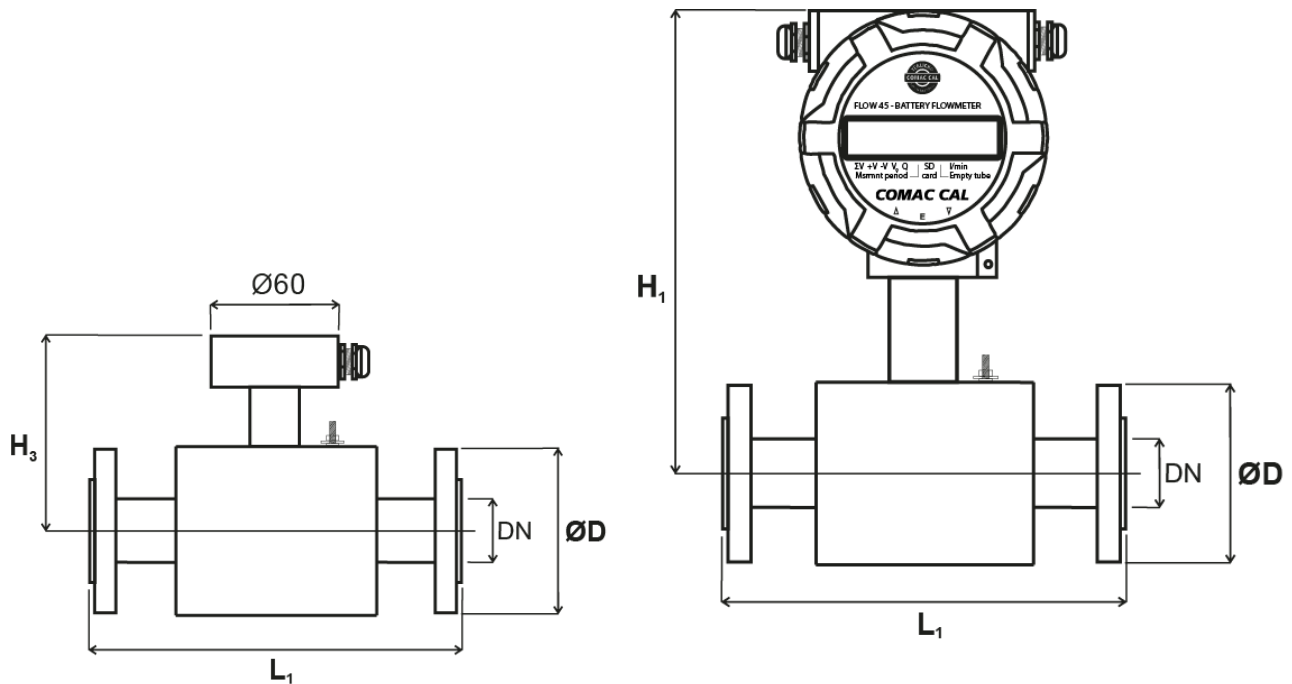

Diameter nominal [mm]	D Outside diameter of flanges	L <sub>1</sub> Building length of sensor	H <sub>3</sub> Building height of sensor	Weight of detached flow sensor (kg)	H <sub>1</sub> Building height of comp. meter	Compact flow meter weight (kg)
10	The outside diameter corresponds to the required pressure class and standards.	200	86	4	173	5
15		200	86	4	173	5
20		200	86	4	173	5
25		200	91	5	178	6
32		200	96	6	183	7
40		200	101	7	188	8
50		200	109	9	196	10
65		200	119	11	206	12
80		200	126	12	213	13
100		250	139	19	226	20
125		250	152	26	239	27
150		300	167	37	254	38
200		350	197	44	284	45

The Table is up to DN 200 for PN25, DN250 and DN300 for PN16, DN350 and DN400 for PN10.

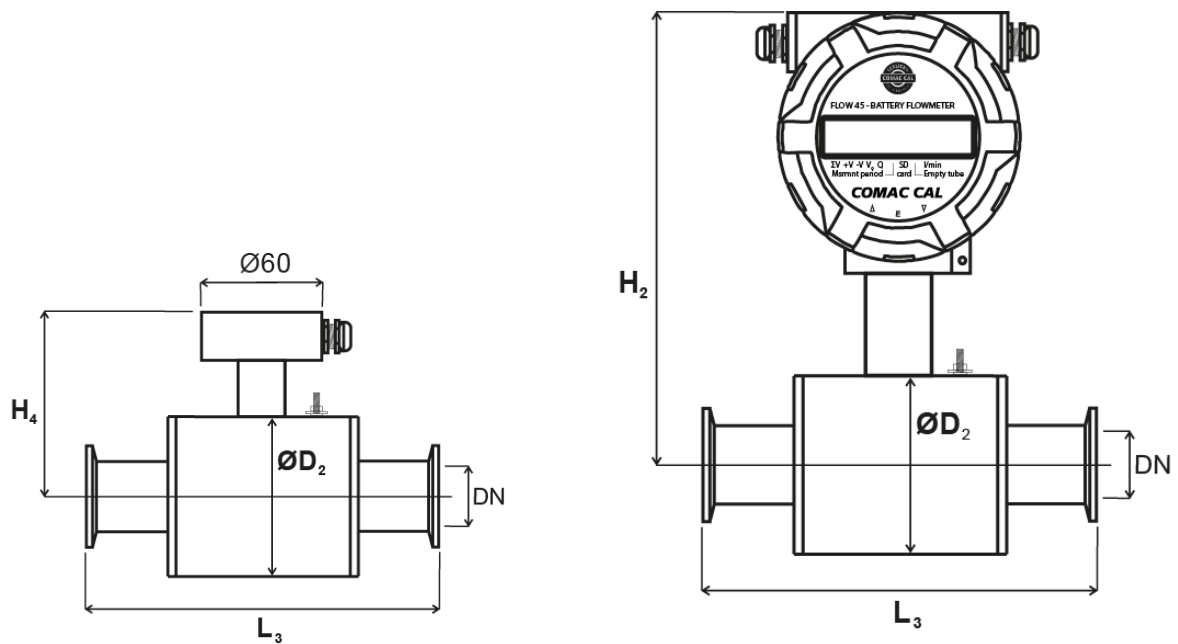

Diameter nominal [mm]	Food grade connection CLAMP/Screwed fitting	D <sub>2</sub> Outside diameter of sensor	L <sub>3</sub> Building length of CLAMP	L <sub>3</sub> Building length of food grade screwed fitting	H <sub>4</sub> Building height of sensor	Weight of detached flow sensor (kg)	H <sub>2</sub> Building height of comp. meter	Compact flow meter weight (kg)
10	DN 10	70	180	173	90	4	177	5
15	DN 15	70	175	165	90	4	177	5
20	DN 20	80	175	170	95	4	182	5
25	DN 25	90	175	180	100	5	187	6
32	DN 32	100	175	192	105	5	192	6
40	DN 40	116	203	215	113	6	200	7
50	DN 50	136	211	228	123	7	210	8

The Table is for PN25.

Diameter nominal [mm]	DN 10...DN 20	DN 25...DN 40	DN 50	DN 65	DN 80
Outside dimension of CLAMP [mm]	34	50,5	64	91	106

## Nomogram for quick proposal of the measured place

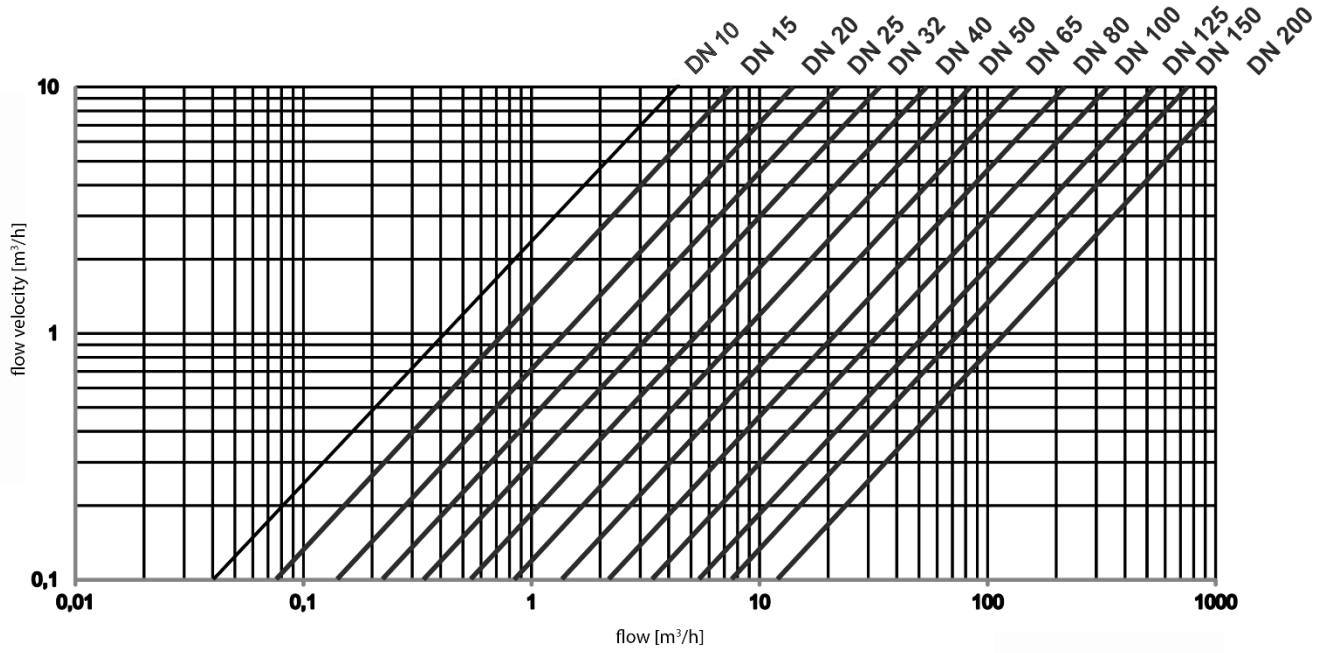

### Reduction in DN pipe

If the pipe's DN is higher than that of the meter selected

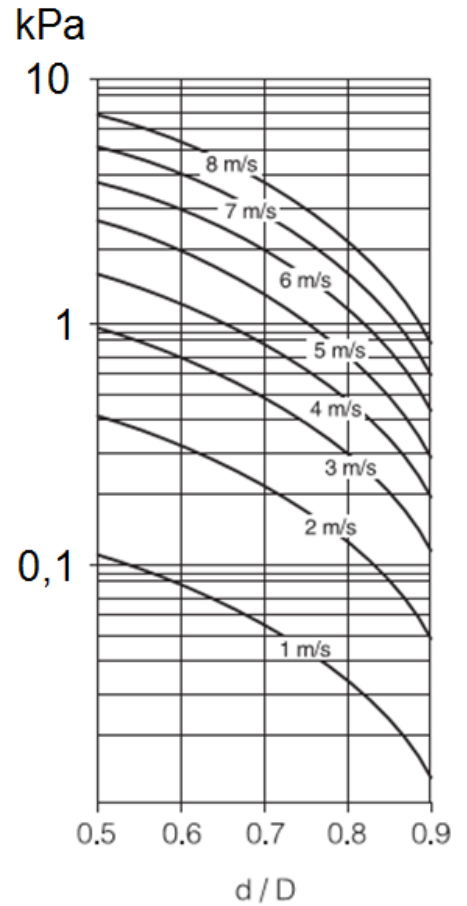
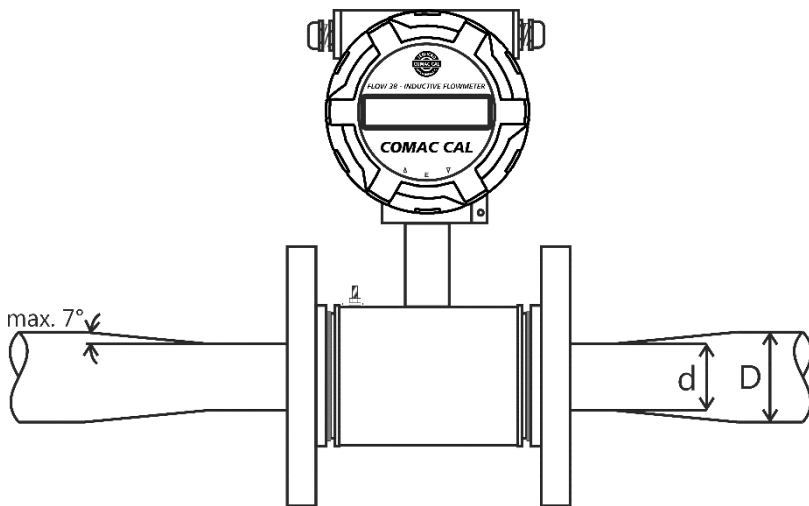

## **Faults and their symptoms during measurement**

Unstable indications and readouts may appear due to:

- big portion of solids
- in homogeneities as a result of the state of matter
- turning point of immixture
- continuous chemical reactions in the measured fluid
- use of diaphragm pumps or plunger pumps
- poor grounding

### ***Flow sensor cleaning***

Some measured liquids contain substances and chemicals that tend to form layers inside the pipes including the measuring pipe, which may affect the measurement accuracy. In this case it is necessary to clean the flow sensor from time to time. Ceramic pipes can be cleaned mechanically with a steel brush and then the cleaning can be completed using diluted hydrochloride acid or citric acid solution. The acid removes calcareous layers or black layers of iron complex. If the contamination is greasy, it must be cleaned by caustic soda or potassium hydroxide solution. Flow sensors with teflon, plastic and rubber measuring pipe cannot be cleaned mechanically with a brush, it is only possible to clean them chemically. After cleaning, the pipe must be properly rinsed with water.

### ***Servicing***

All repairs within warranty and after warranty period are only conducted by the manufacturer, **COMAC CAL s. r.o.**

*When the operations described below are carried out incompetently, the claim for warranty for errors resulting from this becomes null and void !!!*

*Turn off the power every time the evaluation unit is opened !!!*

## *Returning the meter to COMAC CAL s.r.o.*

The meter you have was made with the maximum precision and it has been checked many times and wet calibrated.

If the meter is used in agreement with this manual, the occurrence of faults is very rare. Should they ever occur, contact our service department. If you return the meter to the manufacturing plant, adhere to the conditions stated below:

- Clear the meter of contaminations stuck to the sensor and measuring tube (eventually to the Evaluation Unit).
- If the meter was run with poisonous, etching, combustible liquids or with fluids dangerous to water, check it and if appropriate, flush and neutralize the cavities inside the sensor.

Please attach full description of the fault. COMAC CAL s.r.o. will not be able to process your request promptly and correctly without this form.

### *Order code*

FLOW 45
FL45 H/DNxxx/Ax(cI)/B x/Cx/Dx/Ex/Fx/G1/H1/I1

<p><b>FLOW45</b> (type) H... head</p> <hr/> <p><b>DN</b> (diameter nominal) DN... 10...200</p> <hr/> <p><b>A</b> (design) A1... compact A2... separated (cabel length 3...30 m, T<sub>max</sub> 150 °C) A3... separated (cabel length 3...30 m, T<sub>max</sub> 80 °C)</p> <hr/> <table style="width: 100%; border-collapse: collapse;"> <tr> <td style="width: 50%; vertical-align: top;"><b>B</b> (connection) B1... flanged B2... sandwich B3... threaded B4... diary fitting</td> <td style="width: 50%; vertical-align: top;">B5... clamp B6... stainless steel flange SS304 B7... stainless steel flange SS316</td> </tr> </table> <hr/> <p><b>C</b> (pressure) C1... PN10 (DIN)    C5... PN64 (DIN)    C9... 40K (JIS) C2... PN16 (DIN)    C6... PN100 (DIN)    C10... 150lb (ANSI) C3... PN25 (DIN)    C7... 10K (JIS)    C11... 300lb (ANSI) C4... PN40 (DIN)    C8... 20K (JIS)</p> <hr/> <p><b>D</b> (lining) D1... hard rubber    D4... PTFE    D8... PVDF D2... soft rubber    D5... PFA    D9... RILSAN D3... rubber with potable water test certificate    D6... ceramics*    D7... ETFE</p>	<b>B</b> (connection) B1... flanged B2... sandwich B3... threaded B4... diary fitting	B5... clamp B6... stainless steel flange SS304 B7... stainless steel flange SS316	<p><b>I</b> (measuring range Q<sub>min</sub>/Q<sub>max</sub>) I1... 1/60</p> <hr/> <p><b>H</b> (power) H1... internal lithium battery</p> <hr/> <p><b>G</b> (output) G1... impulse G2... imp. + RS485</p> <hr/> <p><b>F</b> (sensor degree protection) F1... IP65 F2... IP67 F3... IP68</p> <hr/> <p><b>E</b> (electrodes) E1... stainless steel 316 Ti E2... hastelloy C4 E3... titan E4... tantal</p>
<b>B</b> (connection) B1... flanged B2... sandwich B3... threaded B4... diary fitting	B5... clamp B6... stainless steel flange SS304 B7... stainless steel flange SS316		

**Standard set** include installation manual and calibration certificate. For other requirements, please contact the manufacturer directly.  
\* Upon agreement with the manufacturer.